



Hayabusa2 Information

Fact Sheet

Edition time: Immediately after
arrival at the asteroid

Ver. 2.3
2018.07.05

Hayabusa2 Project Team



Table of Contents



1. Overview	3
2. The spacecraft	14
3. History of the mission	54
4. Orbit	77
5. Near-asteroid operations	90
6. Operations	97
7. Target body	104
8. Science	122
9. International cooperation	130



1. Overview



Overview of Hayabusa2



Objective

We will explore and sample the C-type asteroid Ryugu, which is a more primitive type than the S-type asteroid Itokawa that Hayabusa explored, and elucidate interactions between minerals, water, and organic matter in the primitive solar system. By doing so, we will learn about the origin and evolution of Earth, the oceans, and life, and maintain and develop the technologies for deep-space return exploration (as demonstrated with Hayabusa), a field in which Japan leads the world.

Expected results and effects

- By exploring a C-type asteroid, which is rich in water and organic materials, we will clarify interactions between the building blocks of Earth and the evolution of its oceans and life, thereby developing solar system science.
- Japan will further its worldwide lead in this field by taking on the new challenge of obtaining samples from a crater produced by an impacting device.
- We will establish stable technologies for return exploration of solar-system bodies.

Features:

- World's first sample return mission to a C-type asteroid.
- World's first attempt at a rendezvous with an asteroid and performance of observation before and after projectile impact from an impactor.
- Comparison with results from Hayabusa will allow deeper understanding of the distribution, origins, and evolution of materials in the solar system.

International positioning:

- Japan is a leader in the field of primitive body exploration, and visiting a type-C asteroid marks a new accomplishment.
- This mission builds on the originality and successes of the Hayabusa mission. In addition to developing planetary science and solar system exploration technologies in Japan, this mission develops new frontiers in exploration of primitive heavenly bodies.
- NASA too is conducting an asteroid sample return mission, OSIRIS-REx (launch: 2016; asteroid arrival: 2018; Earth return: 2023). We will exchange samples and otherwise promote scientific exchange, and expect further scientific findings through comparison and investigation of the results from both missions.

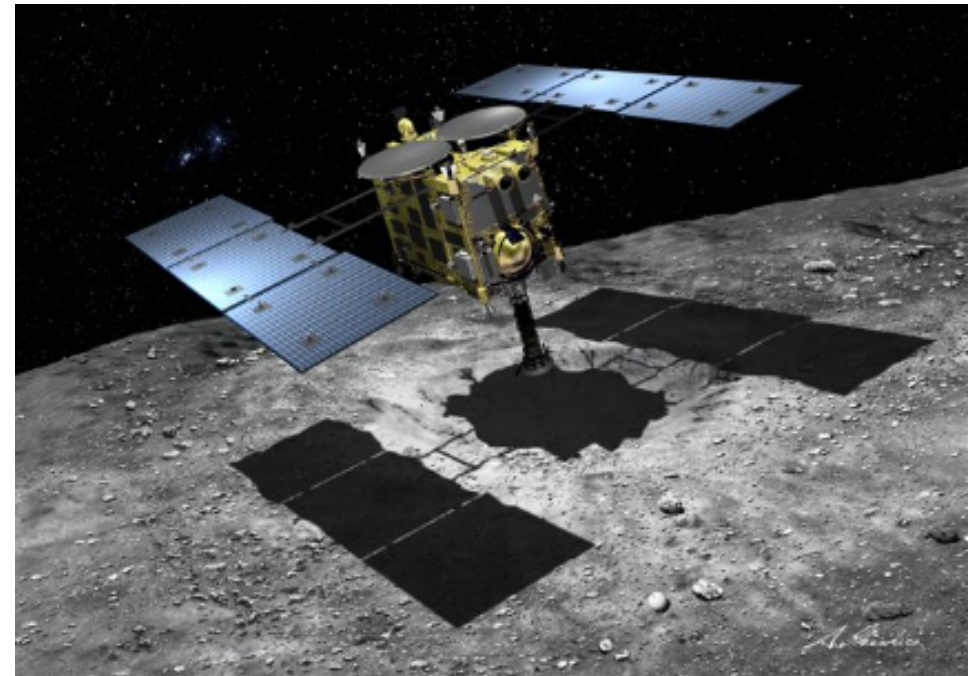

(Illustration: Akihiro Ikeshita)

Hayabusa 2 primary specifications

Mass	Approx. 609 kg
Launch	3 Dec 2014
Mission	Asteroid return
Arrival	27 June 2018
Earth return	2020
Stay at asteroid	Approx. 18 months
Target body	Near-Earth asteroid Ryugu

Primary instruments

Sampling mechanism, re-entry capsule, optical cameras, laser range-finder, scientific observation equipment (near-infrared, thermal infrared), impactor, miniature rovers.



Mission significance



1. Scientific significance

“Where did we come from?”— Origins and evolution of the solar system and the building blocks of life

The materials that formed the Earth, its oceans, and life were present in the primordial cloud from which our solar system formed. In the early solar system, these materials were in contact and able to chemically interact within the same parent objects. These interactions are retained even today in primitive bodies (**C-type asteroids**), so returning samples from these bodies for analysis will elucidate the origins and evolution of the solar system and the building blocks of life.

2. Technical significance

“World-leading technology”— Continuance and development of Japan’s unique deep-space exploration technologies

As the world-first asteroid sample return mission, the Hayabusa mission incorporated a variety of new technologies. Continuing that experience, we will establish technologies that allow more reliable deep space exploration. Taking on these new technical challenges will create new opportunities for the future.

3. Exploration significance

“Exploring new frontiers”—Effects including scientific innovation, contributions to industry and society, improved international presence, youth development

By entering these unexplored fields, we will create new scientific technologies, contribute to industry, and furthermore contribute to society by providing knowledge related to the issue of Earth-threatening asteroids, space resource utilization, and targets for manned exploration.



Mission objectives



- Scientific objective 1: Solving mysteries related to the processes of material evolution in the solar system
We will investigate a type-C asteroid from a materials science perspective. In particular, we will elucidate interactions between minerals, water, and organic materials.
- Scientific objective 2: Solving mysteries related to the evolutionary process of planets
We will examine the formation process of asteroids through direct study of the integration of materials into asteroids, their internal structure, and subsurface material.
- Engineering objective 1: Establishment of technologies for deep space sample return exploration
We will bring these technologies to maturity by improving their robustness, stability, and operability.
- Engineering objective 2: Demonstration of space impactor technology
We will demonstrate collision of an impactor on a celestial body.



Mission flow

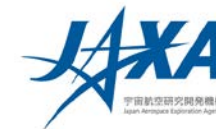

Launch
3 Dec 2014

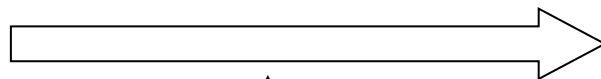

Arrival at asteroid
27 Jun 2018

▲
Earth swing-by
3 Dec 2015

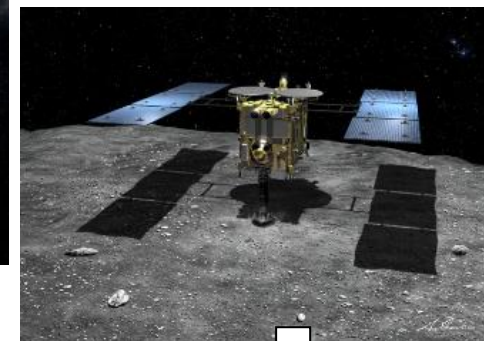

Examine the asteroid by remote sensing observations. Next, release a small lander and rover and also obtain samples from the surface.

Earth return
Late 2020

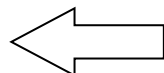

Depart asteroid
Nov–Dec 2019



Create artificial crater

Release impactor

After confirming safety, touchdown within the crater and obtain subsurface samples

Use an impactor to create an artificial crater on the asteroid's surface

Sample analysis



Planned operations



- Depart Earth
- IES trial
- Begin IES-powered flight



- Earth swing-by
- Subsequent long-term IES operation



- Asteroid rendezvous by optical navigation



- Maintain position
- Global mapping of the asteroid by proximity observations

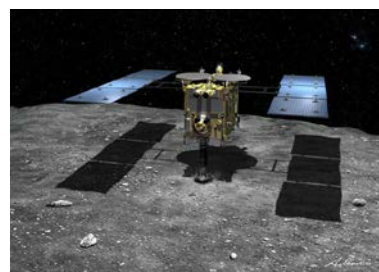

- Landing practice & implementation
- Lander/rover separation
- Touchdown and sampling



- Interim operations



- Impactor operations (crater creation)
- Debris/ejecta avoidance operations



- Touchdown in artificial crater



- Depart asteroid



- Earth re-entry

(Illustrations: Akihiro Ikeshita)



Overall schedule

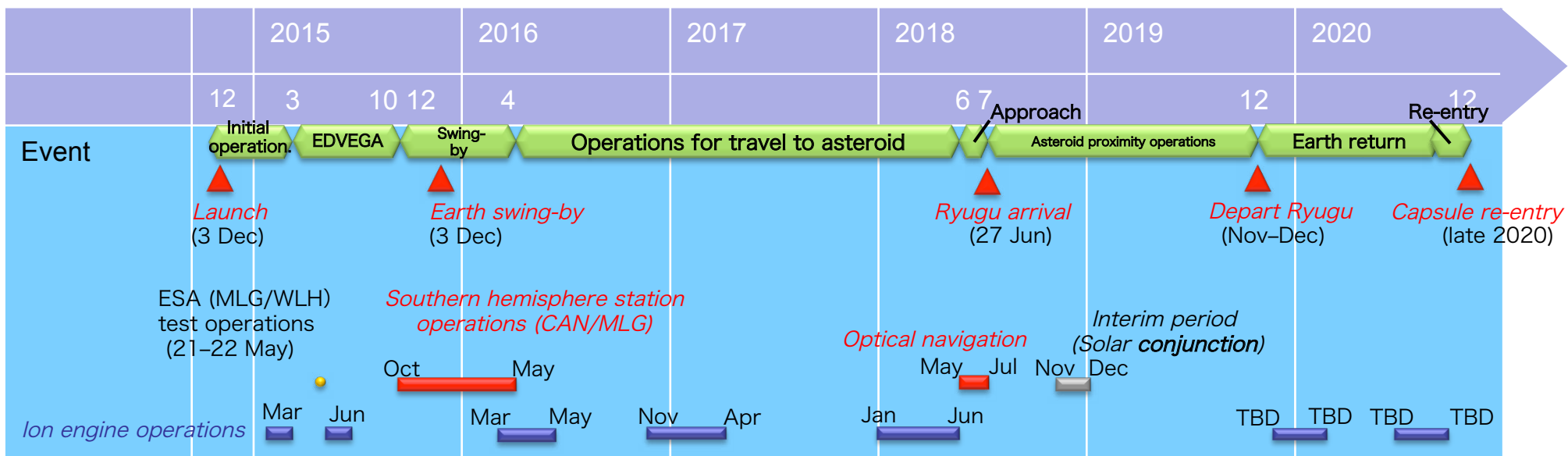



Preliminary asteroid approach schedule



Year	Month/Day	Item	Status
2018	10 Jan	Phase 3 ion engine operations begin	Complete
	3 Jun	Ion engine operation ends	Complete
	3 Jun	Start of asteroid approach (dist. 3,100 km)	Complete
	27 Jun	Arrive at asteroid (alt. 20 km)	Complete
	Late Jul	Medium altitude observation #1 (alt. 5 km)	Est.
	Aug	Gravity measurement descent (alt. 1 km)	Est.
	Late Aug	Decision of landing sites	Est.
	Sep–Oct	Touchdown operation slot #1	Est.
	Sep–Oct	Rover descent operation slot #1	Est.
	Nov–Dec	Interim operations (communication unavailable)	Est.
2019	Jan	Medium altitude observation #2 (alt. 5 km)	Est.
	Feb	Touchdown operation slot #2	Est.
	Mar–Apr	Crater creation operations	Est.
	Apr–May	Touchdown operation slot #3	Est.
	Jul	Rover descent operation slot #2	Est.
	Aug–Nov	Stay in asteroid vicinity	Est.
	Nov–Dec	Depart asteroid	Est.

Note that the above schedule is subject to change according to various factors after arrival at Ryugu; all dates are tentative, other than those marked “complete.”



Mission patch



Initial version



From preparation through launch, the JAXA SPace Exploration Center (JSPEC, the program group for lunar and planetary exploration) primarily led the Hayabusa2 project. The patch shows touchdown on the target asteroid 1999 JU₃. The path past the Earth, Moon, and Mars indicates our intent to advance technologies and science for future solar system exploration. The shape of the red background indicates the two high-gain antennas that are characteristic of Hayabusa2.

Version from Earth swing-by to asteroid arrival

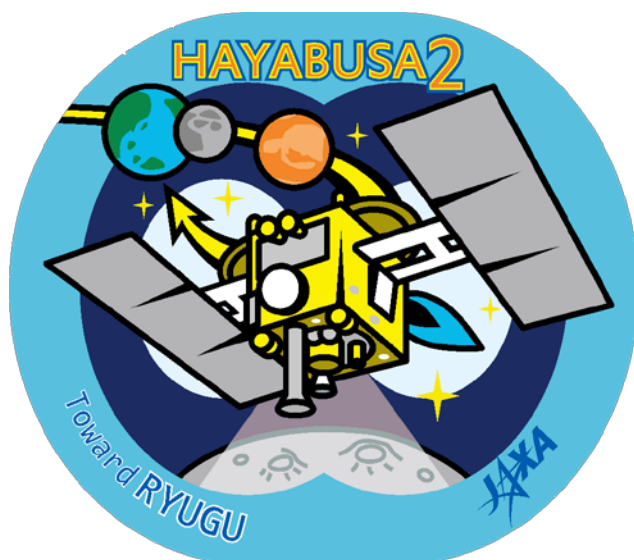

With the 3 Dec 2015 Earth swing-by and start of the approach toward Ryugu (the asteroid was named in Sept. 2015), we changed the background colors to blue, indicating departure from the vicinity of Earth and plunging deeper into space. This works well with imagery from the Japanese folk tale from which Ryugu gets its name: Urashima Taro rode on a sea turtle's back to Ryugu Palace, deep beneath the ocean.

(© JAXA)



Mission patch

Version from asteroid arrival



Since Hayabusa2 arrived at Ryugu on June 27, 2018, the color and a part of illustration have been. The outermost vermilion shades represent the palace of Ryugu; the location in the Japanese folk tale of Urashima Taro that asteroid Ryugu takes its name. The inner purple is for the nobles of the palace and Princess Otohime, while the central light blue is for the princess's feathered robe. These changing colors show the enthusiasm of the Project members to explore the whole of Ryugu. The logo also shows an illustration of the asteroid, with the large craters and boulders that have now been seen on the surface.



Asteroid exploration at JAXA/ISAS



Hayabusa

Hayabusa2

Subsequent missions

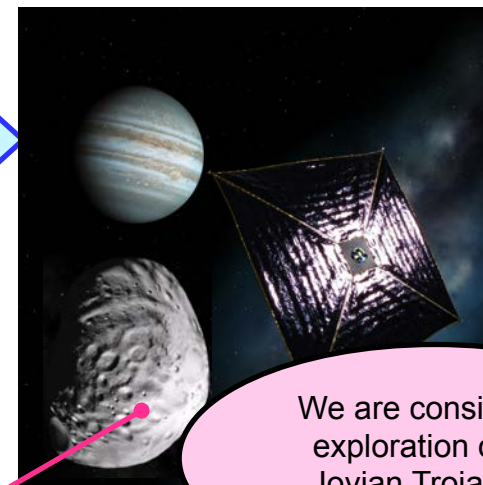
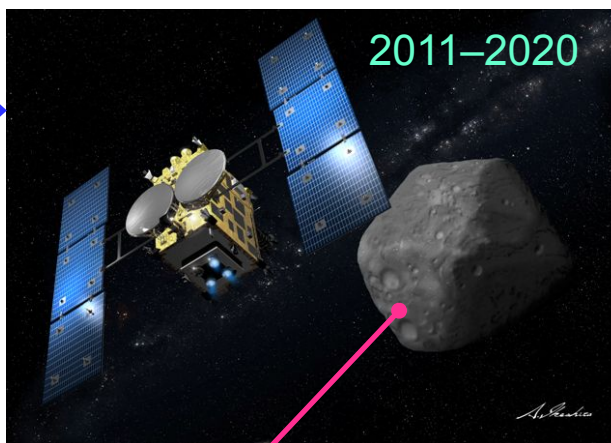
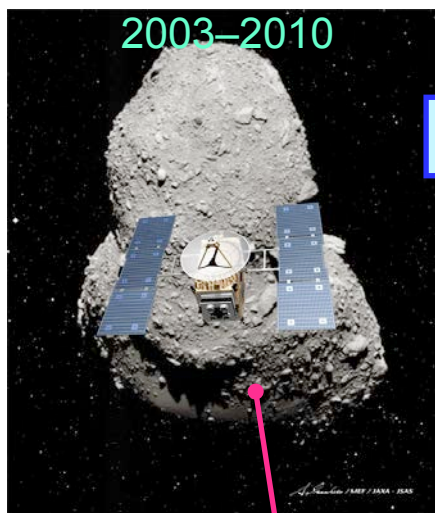

We are considering exploration of the Jovian Trojans by solar sail

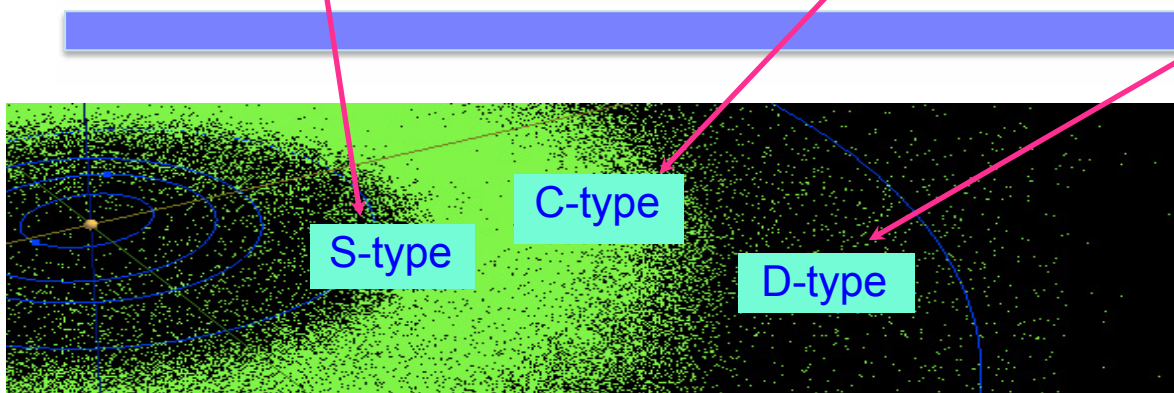

Asteroid belt

To more primitive bodies

To more advanced technologies

To farther distances

Note: Ryugu is a C-type asteroid, exceptional in that it exists near the orbits of Earth and Mars.



History of asteroid exploration planning

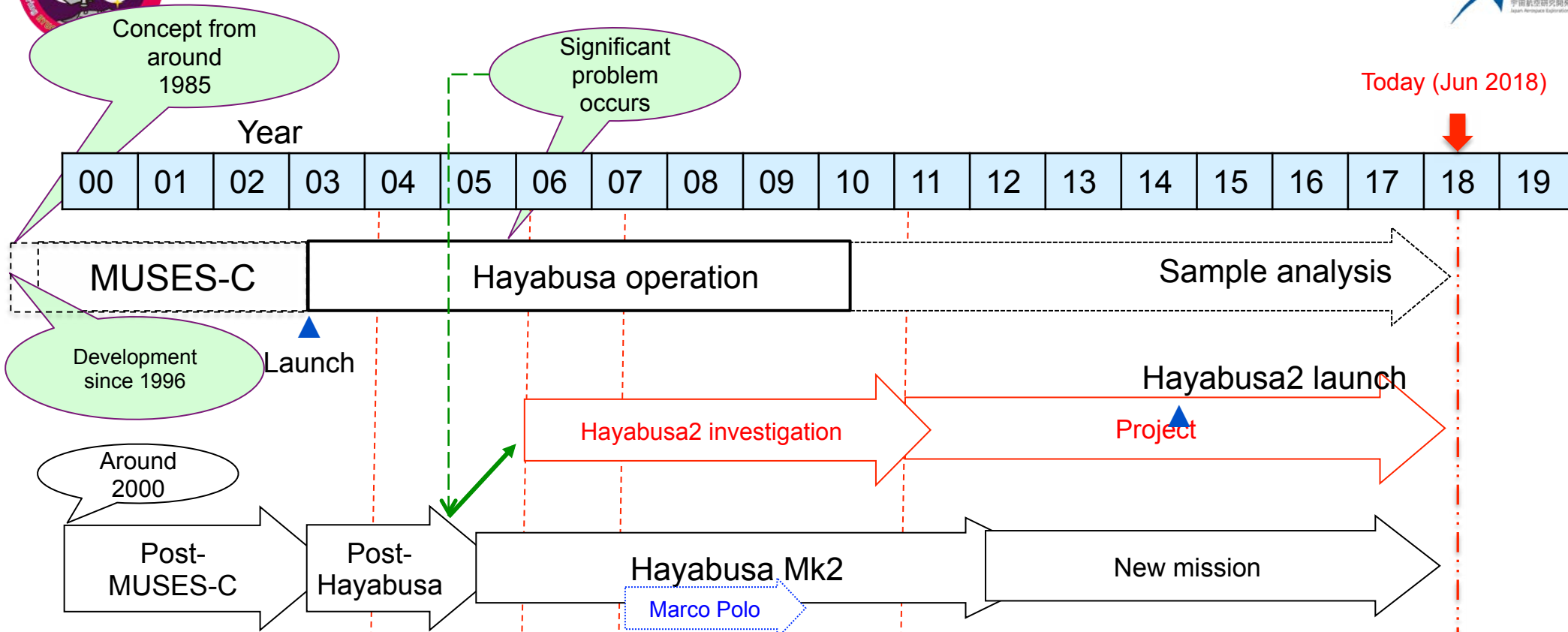

Today (Jun 2018)



Apr 2004: Launch of small body exploration working group

2006: Start investigation of Hayabusa2 mission

Jun 2007: Launch of Hayabusa2 prep. team

May 2011: Launch of Hayabusa2 project team

Started as a "revenge" mission for Hayabusa, initially as a "copy" spacecraft; target launch of 2010

Hayabusa 2 reviews, etc.

- 2006.10–11 : Mission definition review (MDR), system requirements review (SRR), system definition review (SDR)→ 2010 launch
- 2009.6–7 : ΔMDR (mission scope expansion)→ 2014 launch
- 2009.12 : SRR
- 2010.8 : Space Development Committee pre-evaluation #1
- 2011.3 : SDR
- 2011.4–9 : Preliminary design review (PDR)
- 2011.6–2012.1 : Space Development Committee pre-evaluation #2
- 2012.3 : Critical design review (CDR)



2. The spacecraft



Primary spacecraft components

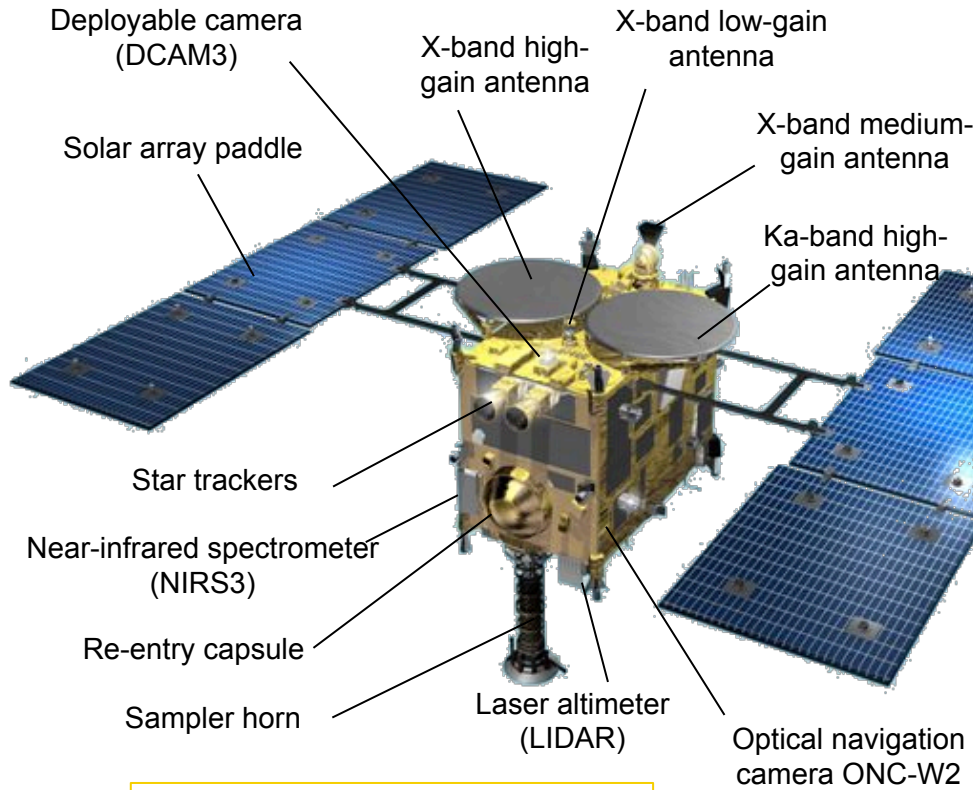

Optical navigation camera ONC-T

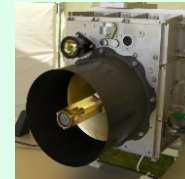

Laser altimeter LIDAR

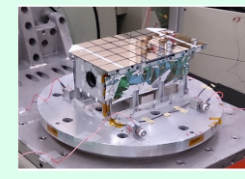

Near-infrared spectrometer NIRS3

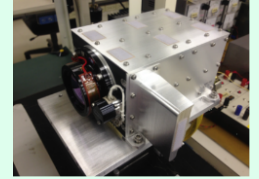

Thermal infrared camera TIR

Scientific observation equipment

Small lander & rover

MASCOT



Created by DLR and CNES

Minerva 2



II-1A



II-1B

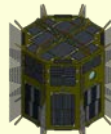

II-2

II-1: By the JAXA Minerva-II team

II-2: By Tohoku Univ. & the Minerva-II Consortium

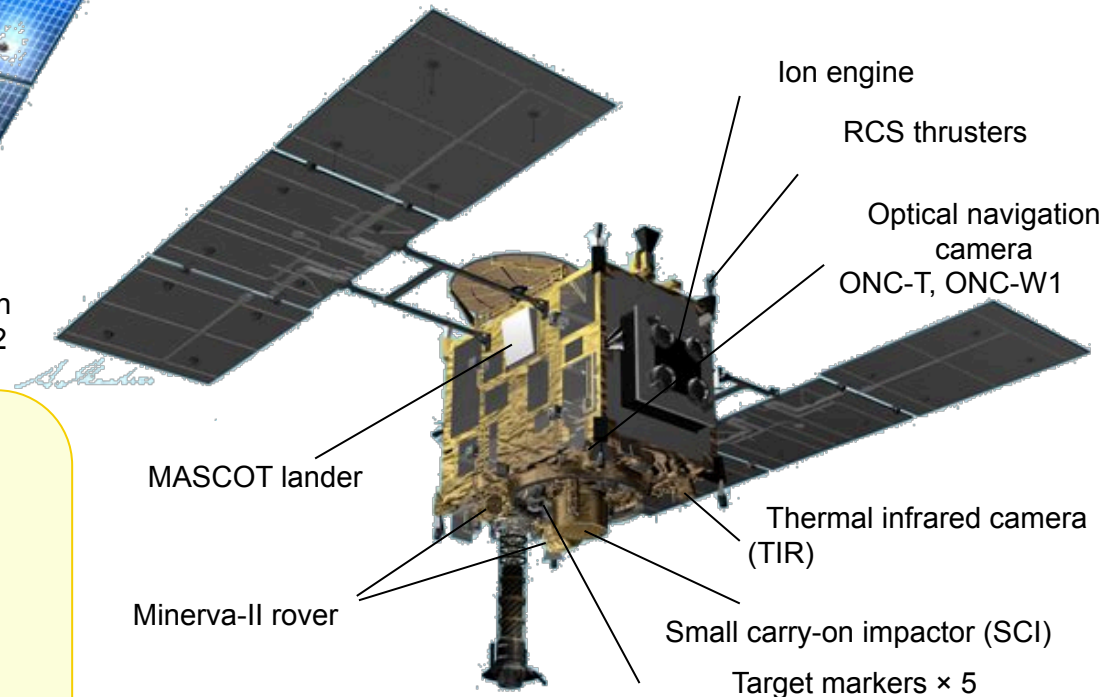

Size: 1 × 1.6 × 1.25 m (main body)
 Solar paddle deployed width 6 m
 Mass : 609 kg (incl. fuel)



Device names (1/2)

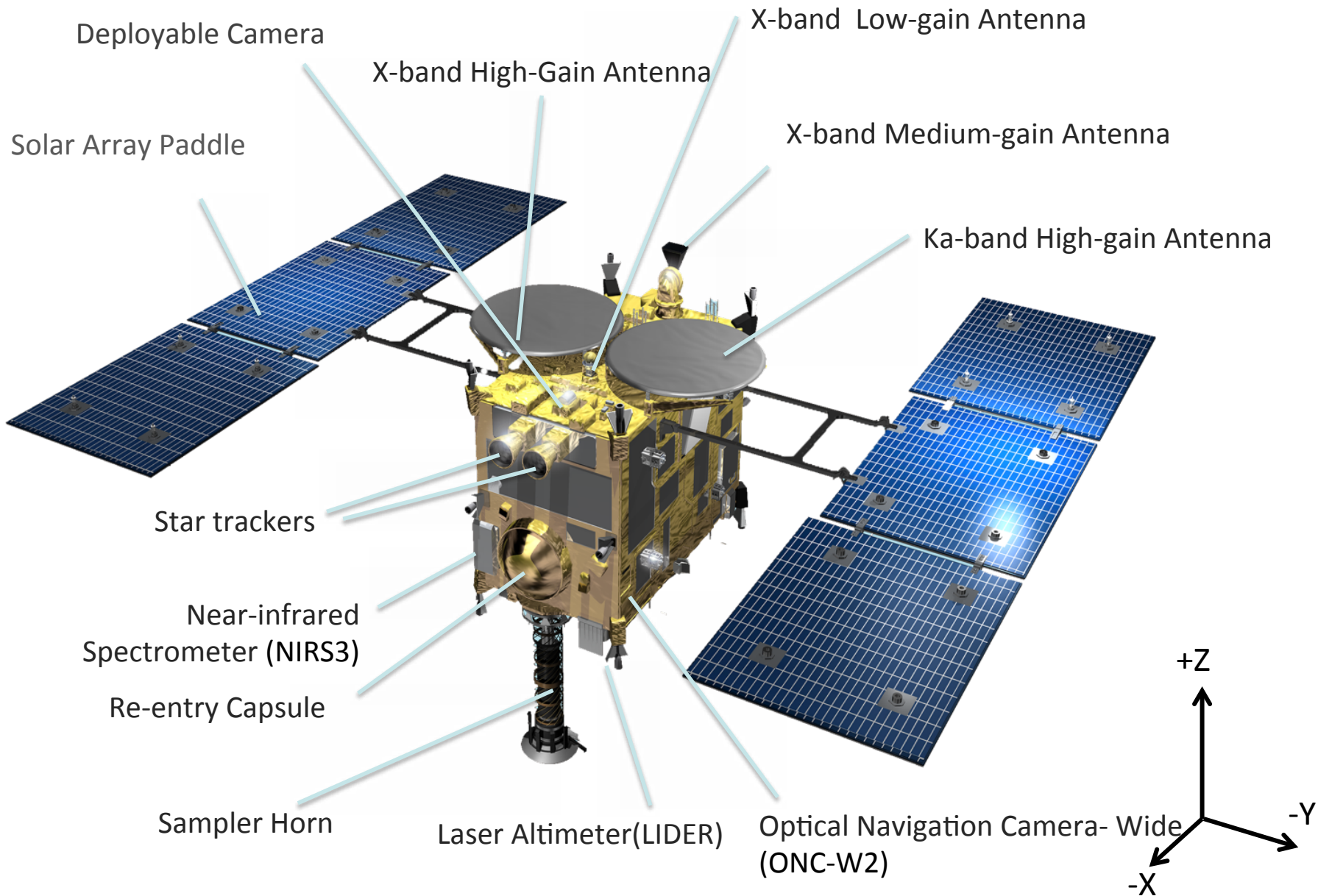

(© JAXA)



Device names (2/2)

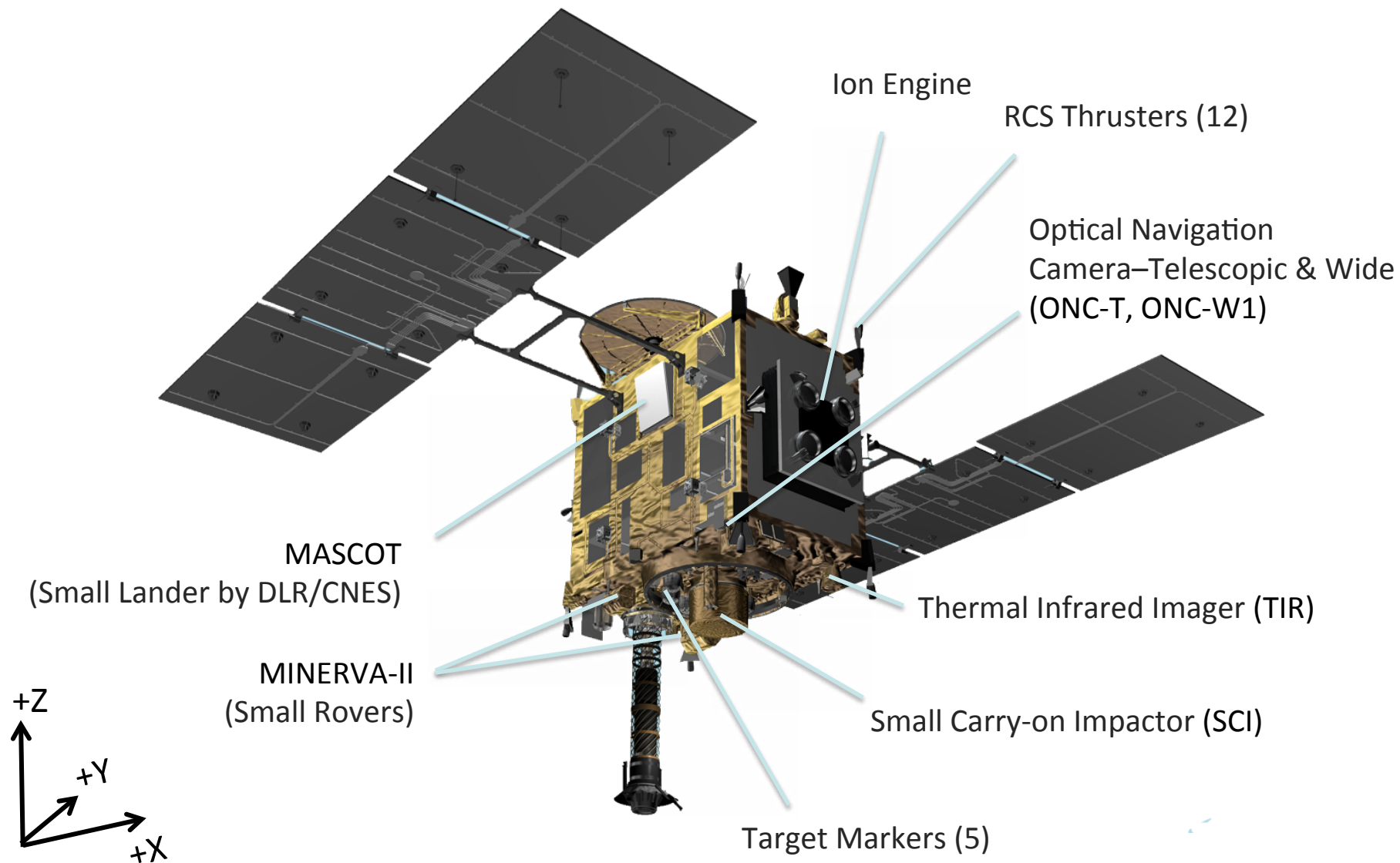

(© JAXA)



Spacecraft dimensions

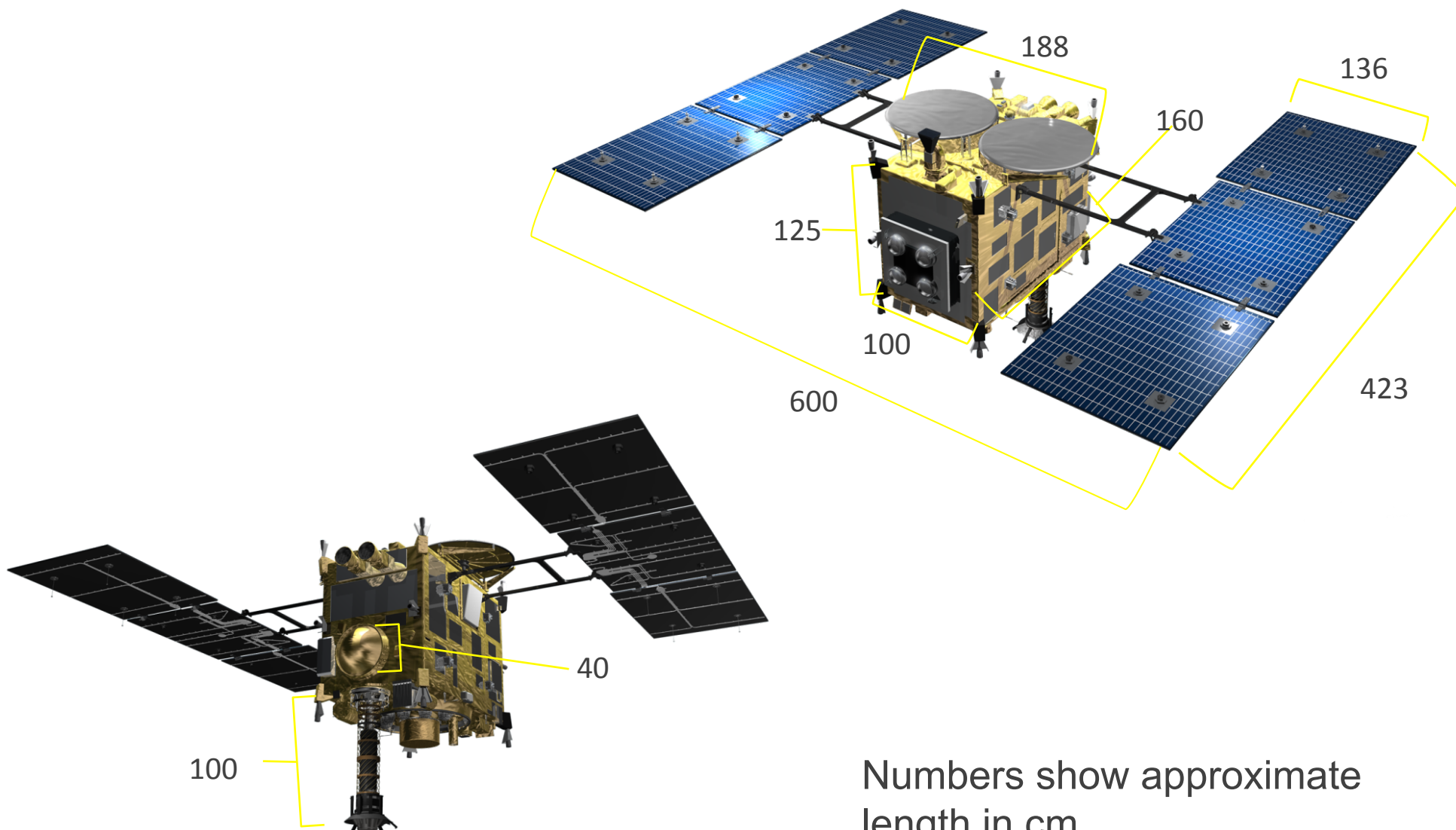
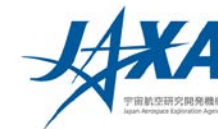

Numbers show approximate length in cm

(© JAXA)



Primary engagement testing

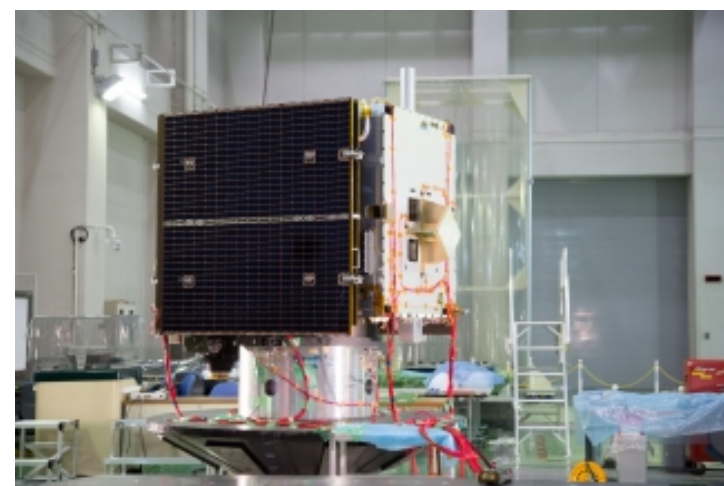
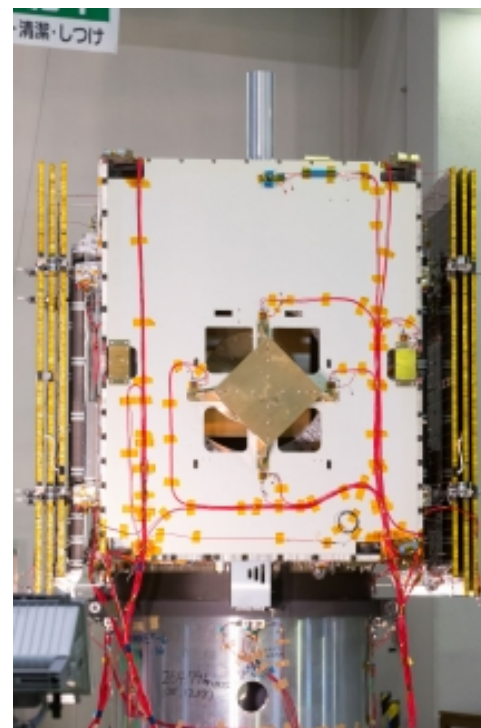
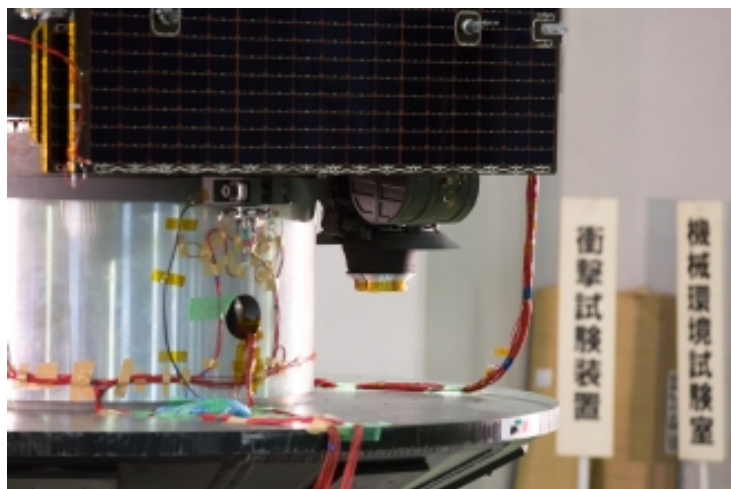

(© JAXA)

26 Dec 2012: JAXA Sagamihara Campus



Completion of primary engagement testing

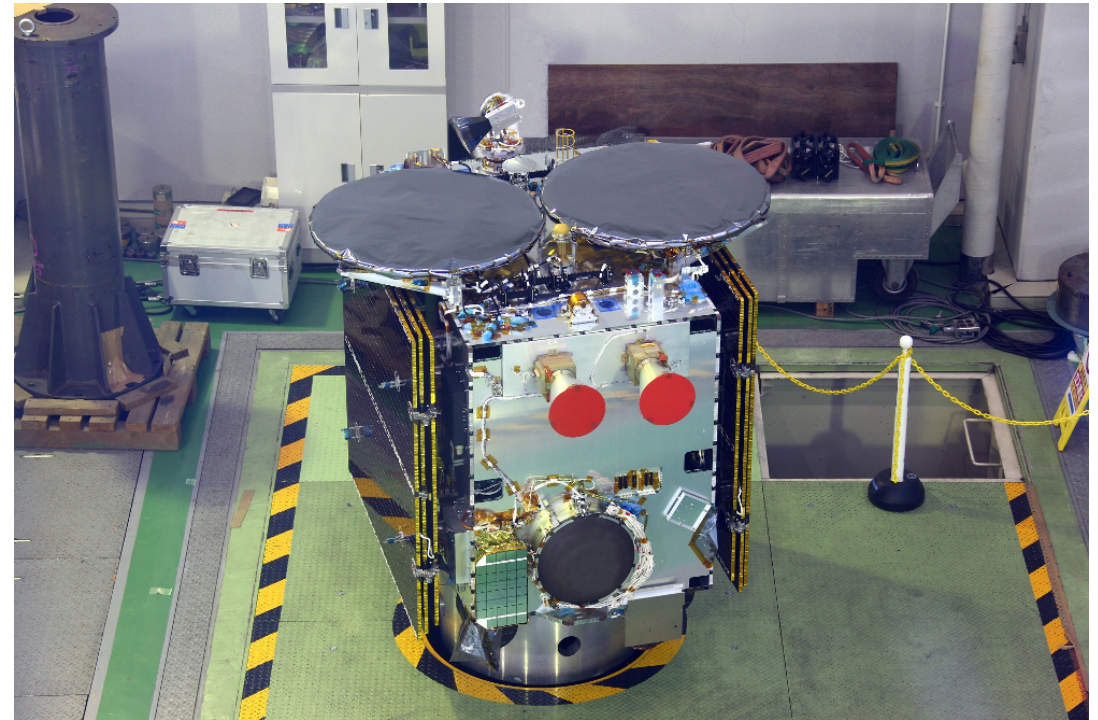
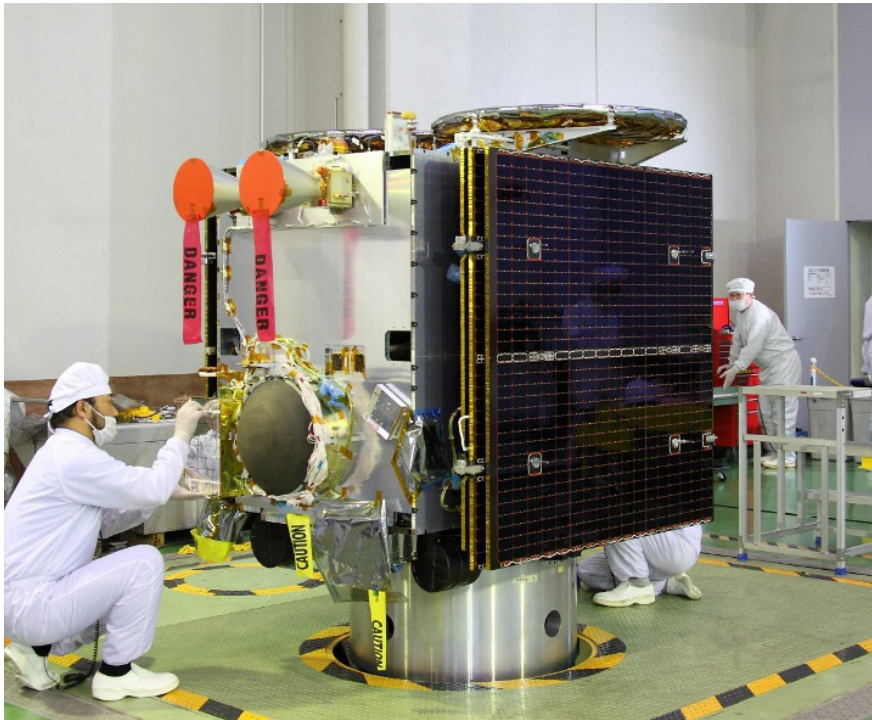

Jun 2013: JAXA Sagamihara Campus

(© JAXA)



Flight model



31 Aug 2014: JAXA Sagamihara Campus

(© JAXA)



Comparison of Hayabusa and Hayabusa2 (1/3)



Hayabusa

Hayabusa2

Dimensions: Approx. 1 × 1.6 × 1.1 m (main body)
Mass: 510 kg (with fuel)

Dimensions: Approx. 1 × 1.6 × 1.25m (main body)
Mass: 600 kg (with fuel)

Top view

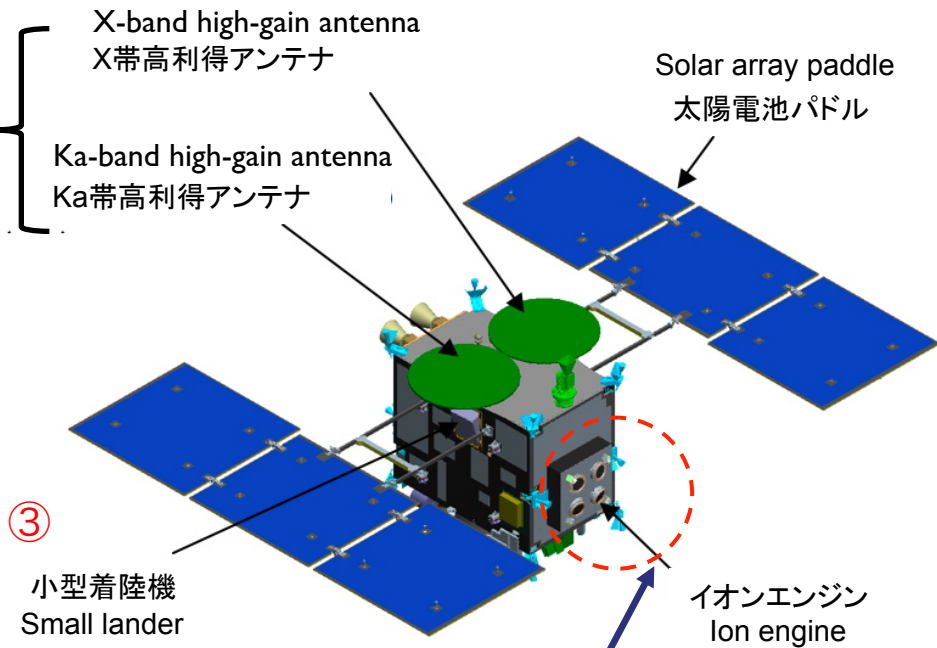
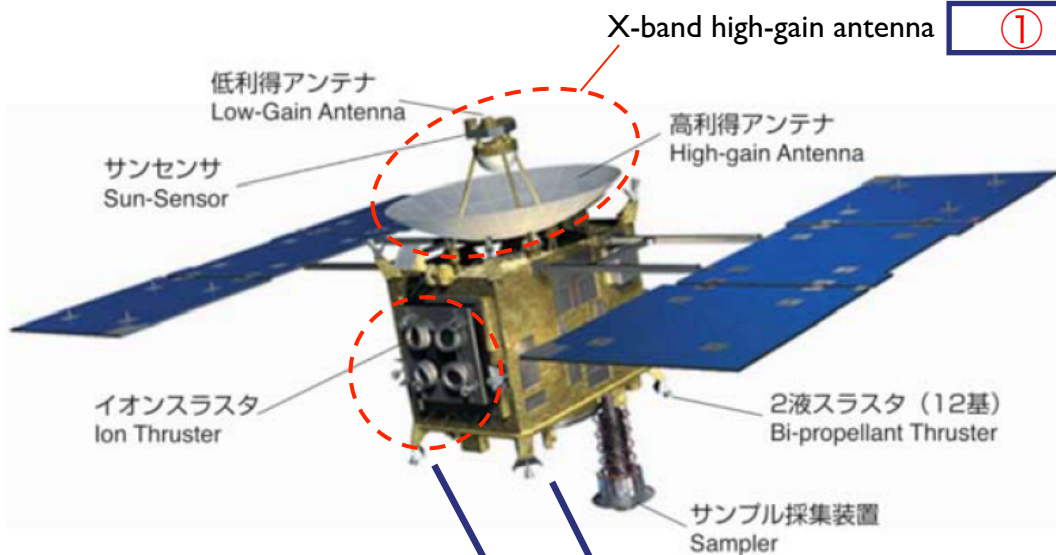

(© JAXA)

Improvements over Hayabusa

- ① Communication system: A new Ka-band communication system was added for high-speed communication. The high-gain antenna was made into a planar antenna.
- ② Ion engine: Improved durability, stronger propulsion
- ③ Mobile Asteroid Surface Scout (MASCOT) small lander: Developed in Germany and France for landing and data acquisition on an asteroid surface.
- ④ Attitude control device (reaction wheel): Two of the three installed on Hayabusa malfunctioned, so four are mounted on Hayabusa2 and further measures have been taken to avoid problems.



Comparison of Hayabusa and Hayabusa2 (2/3)



Hayabusa

Hayabusa2

Bottom view

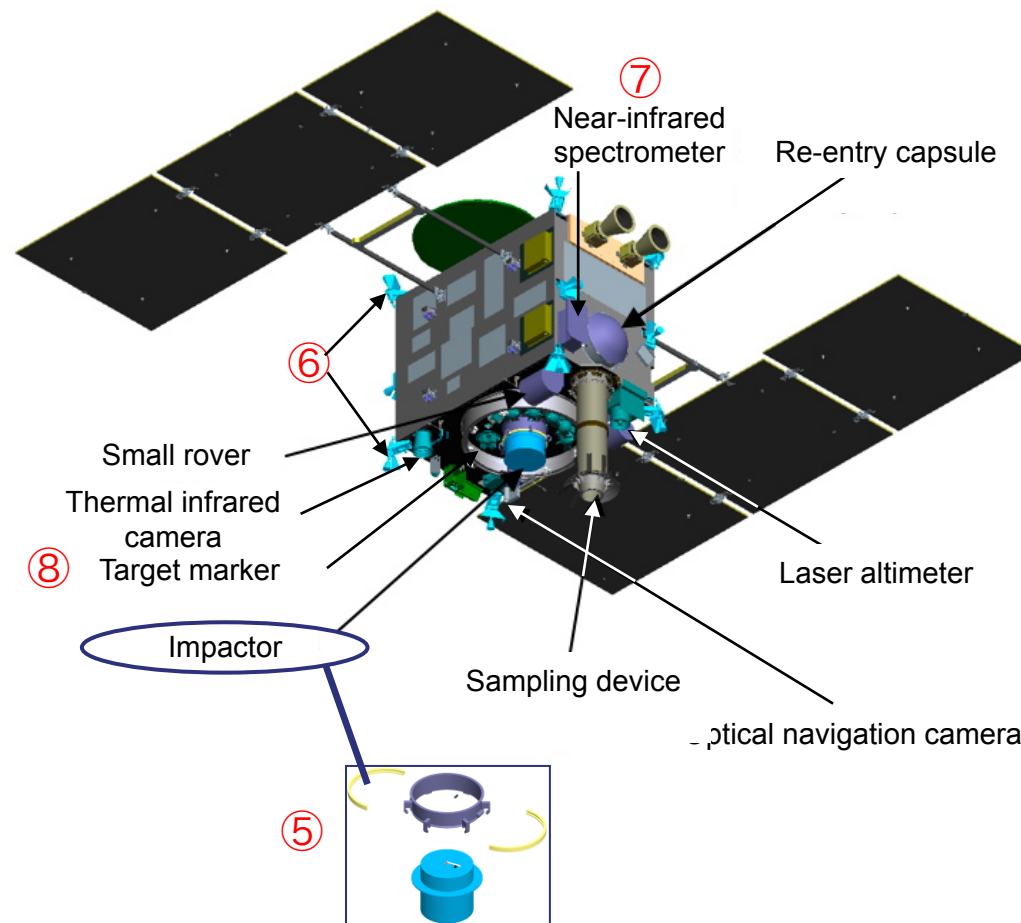
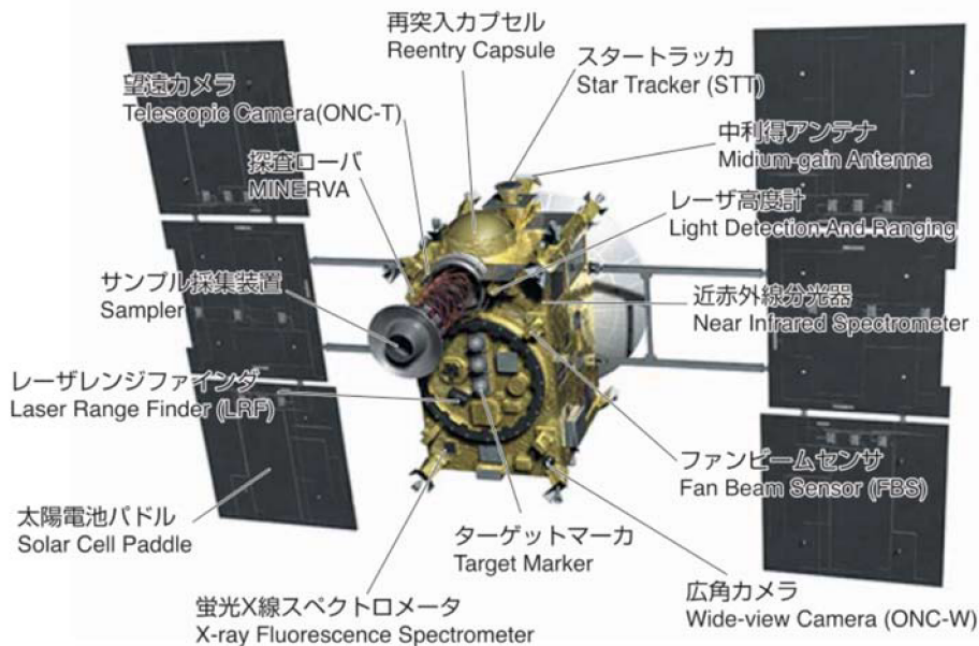

(© JAXA)

Improvements over Hayabusa

- ⑤ Impactor: A new device for creating an artificial crater on the asteroid surface, then collecting subsurface materials.
- ⑥ RCS thrusters: Improved propellant plumbing as a countermeasure against the malfunctions on Hayabusa and Akatsuki.
- ⑦ Mission equipment: Newly developed and improved equipment for exploration of a type-C asteroid.
- ⑧ Target markers: Increased from three on Hayabusa to five on Hayabusa2 to realize a pinpoint landing.



Comparison of Hayabusa and Hayabusa2 (3/3)



	Hayabusa	Hayabusa 2
Main body dimensions	1 × 1.6 × 1.1 m	1 × 1.6 × 1.25 m
Mass (with fuel)	510 kg	609 kg
Launch year and rocket	9 May 2003, M-V-5 rocket	3 Dec 2014, H-IIA rocket flight 26
Communications frequencies	X-band (7–8 GHz)	X-band (7–8 GHz)、Ka-band (32 GHz)
Mission equipment	Near-infrared spectrometer, fluorescent X-ray spectrometer, multiband spectroscopic camera, laser altimeter, MINERVA, sampler	Near-infrared spectrometer, thermal infrared camera, optical navigation camera, laser altimeter, MINERVA-II, MASCOT, impactor, separation camera, sampling device
Exploration period	Approx. 3 months	Approx. 18 months (planned)
Samples	2 (surface only)	3 (surface and attempted subsurface)
Earth return	13 Jun 2010	Late 2020 (planned)



List of mission equipment



Device	Role
Optical Navigation Camera (ONC)	Telescopic and wide-angle cameras centered on visible wavelengths, with respective viewing angles of 6 and 60 deg. These are used for scientific observations and navigation.
Near-infrared spectrometer (NIRS3)	Performs spectroscopic observations of near-infrared rays including the 3-micron band. The viewing angle is about 0.1 deg.
Thermal infrared spectrometer (TIR)	Images the asteroid at mid-infrared ranges including the 10-micron band. Viewing angle is a little over 10 deg.
Laser altimeter (LIDAR)	Measures the distance between the probe and the asteroid surface. Also acquires scientific data such as asteroid topography, gravity, and albedo. Measurement ranges are 30 m–25 km.
Sampling device (SMP)	Acquires samples from the asteroid surface. Slight improvements over the Hayabusa sampling device.
Impactor (SCI)	Accelerates a 2-kg copper mass to 2 km/s to collide with the asteroid surface, forming an artificial crater.
Deployable camera (DCAM)	Separates from the spacecraft to image the impactor operation.
Small rovers (MINERVA-II-1 (A, B), 2)	Descends to the asteroid surface for investigations. Three rovers similar to MINERVA mounted on Hayabusa.
Small lander (MASCOT)	Descends to the asteroid surface to acquire data through four observation devices. Created by DLR (Germany) and CNES (France). Observation devices: MicrOmega, MAG, CAM, MARA



Remote sensing equipment

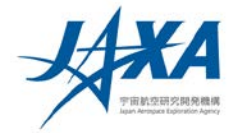

Optical Navigation Camera (ONC)

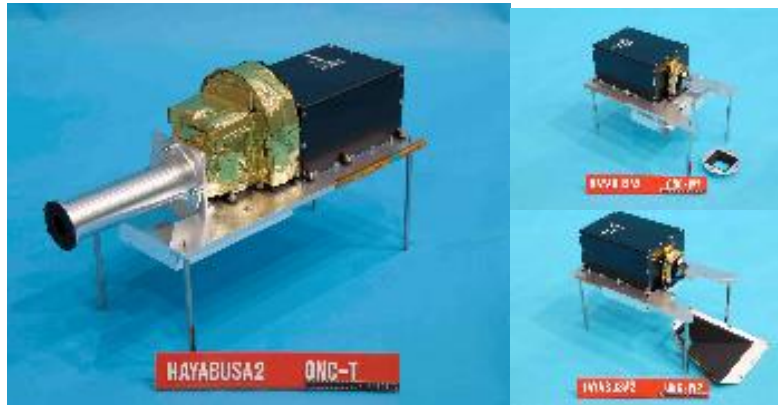

ONC-T (telescopic) ONC-W1, W2 (wide-angle)
Imaging for scientific observation and navigation

Thermal Infrared Camera (TIR)

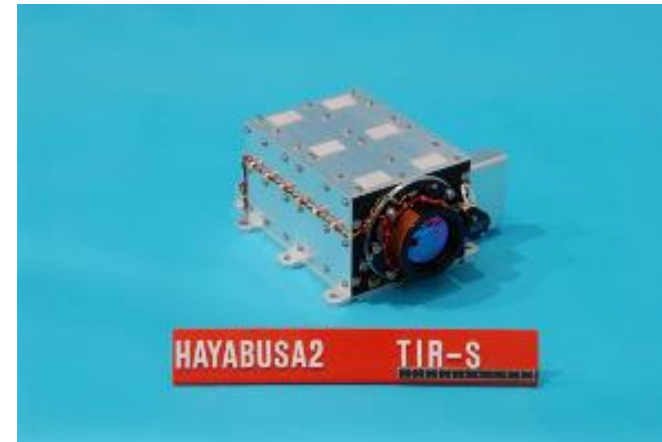

8–12 μm imaging: Measures asteroid surface temperature

Near-infrared Spectrometer (NIRS3)

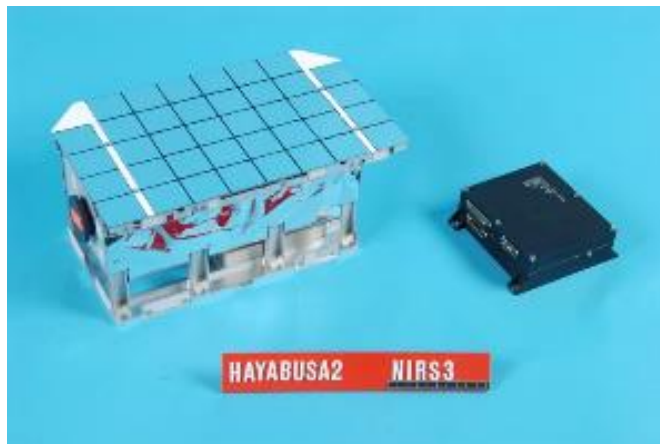

Infrared spectra including the 3- μm band: investigates mineral distributions on the asteroid surface

Laser Altimeter (LIDAR)



Measures distance between the asteroid and the spacecraft in a range of 30 m–25 km



Optical navigation camera (ONC)



ONC: Optical Navigation Camera



Objective: Images fixed stars and the target asteroid for spacecraft guidance and scientific measurements

Scientific measurements:

- Form and motion of the asteroid:
 - Diameter, volume, direction of inertial principal axis, nutation
- Global observations of surface topography
 - Craters, structural topography, rubble, regolith distribution
- Global observations of spectroscopic properties of surface materials
 - Hydrous mineral distribution, distribution of organic matter, degree of space weathering
- High-resolution imaging near the sampling point
 - Size, form, degree of bonding, and heterogeneity of surface particles; observation of sampler projectiles and surface markings



- Elucidation of features of target asteroid
- Distribution of **hydrous minerals and organic matter**, space weathering, boulders
- Sampling site selection
- Basic information on where to collect asteroid samples
- Ascertaining sample state
- **High-resolution imaging** of sampling sites

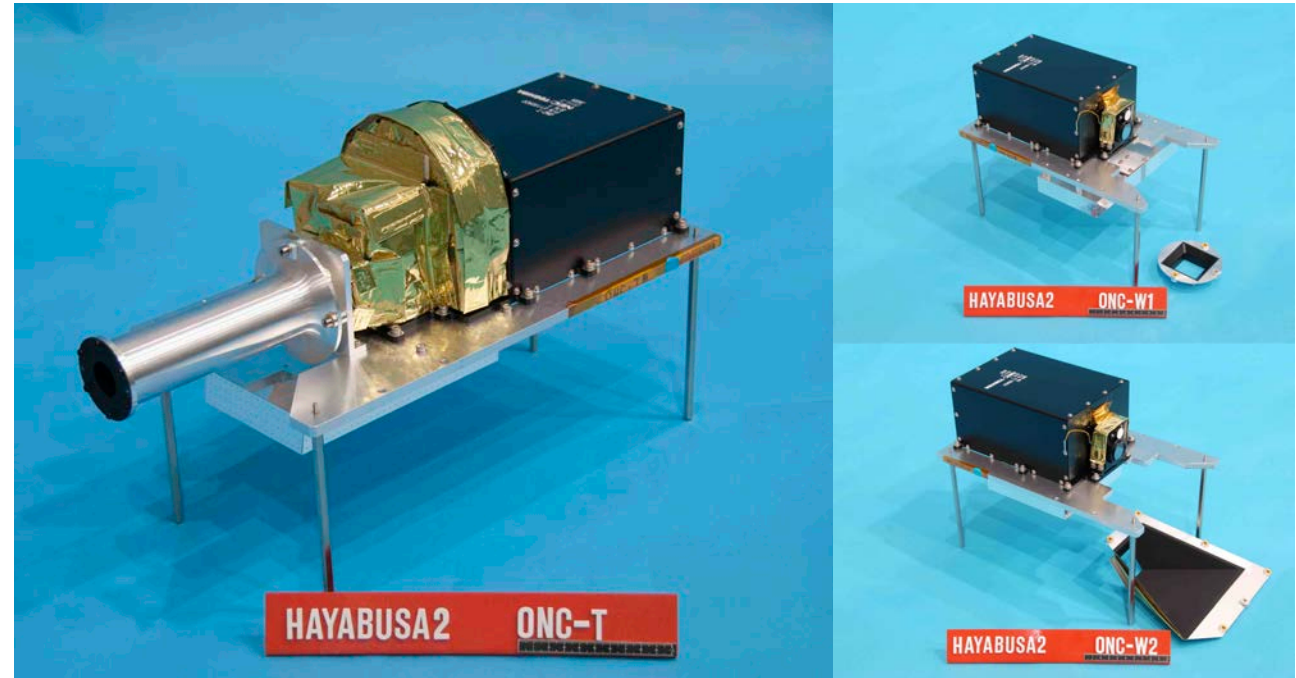
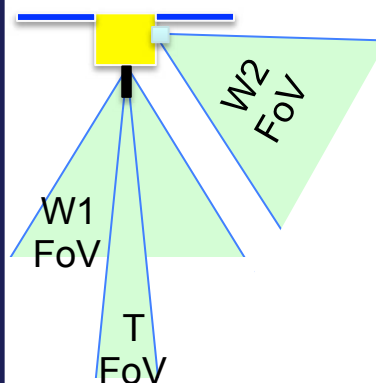

	ONC-T	ONC-W1	ONC-W2
Detector	2D Si-CCD (1024 × 1024 px)		
Viewing direction	Downward (telescopic)	Downward (wide-angle)	Sideward (wide-angle)
Viewing angle	6.35° × 6.35°	65.24° × 65.24°	
Focal length	100 m–∞	1 m–∞	
Spatial resolution	1 m/px @ 10-km alt. 1 cm/px @ 100-m alt.	10 m/px @ 10-km alt. 1 mm/px @ 1-m alt.	
Observation wavelength	390, 480, 550, 700, 860, 950, 589.5 nm, and wide	485–655 nm	



Laser altimeter (LIDAR)



LIDAR: Light Detection And Ranging

- Pulse-type laser altimeter
- A pulse YAG laser with a 1.064- μm wavelength is emitted toward the target object, and the altitude is measured by measuring the return time of the laser beam.
- The LIDAR aboard Hayabusa 2 could perform measurements from 30 m–25 km.
- LIDAR is a navigation sensor used for approach and landing at a target, and a scientific observation device used to measure shape, gravity, and surface characteristics, and for dust observations.
- It also has a transponder function that can perform space laser ranging (SLR) experiments with ground LIDAR stations.

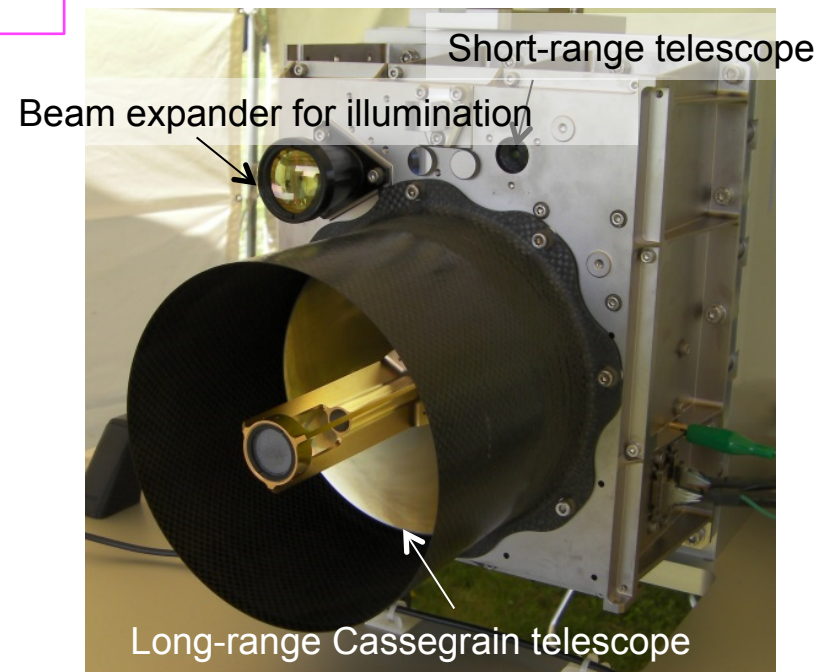

Laser altimeter engineering model

Scientific objectives

- Terrain and gravity field observations of the target asteroid
- Observations of albedo distribution at various surface points
- Observations of dust floating around the asteroid



- Asteroid form, mass, porosity, and deviation
- Asteroid surface roughness
- Dust floating phenomena



Near-infrared spectrometer (NIRS3)



NIRS3: Near-infrared Spectrometer (‘3’ from 3 μm)

Infrared absorption of hydroxyl groups and water molecules is observed in 3-μm band reflection spectra in the near-infrared region. NIRS3 investigates distributions of hydrous minerals on the asteroid surface by measuring reflection spectra in the 3-μm band.

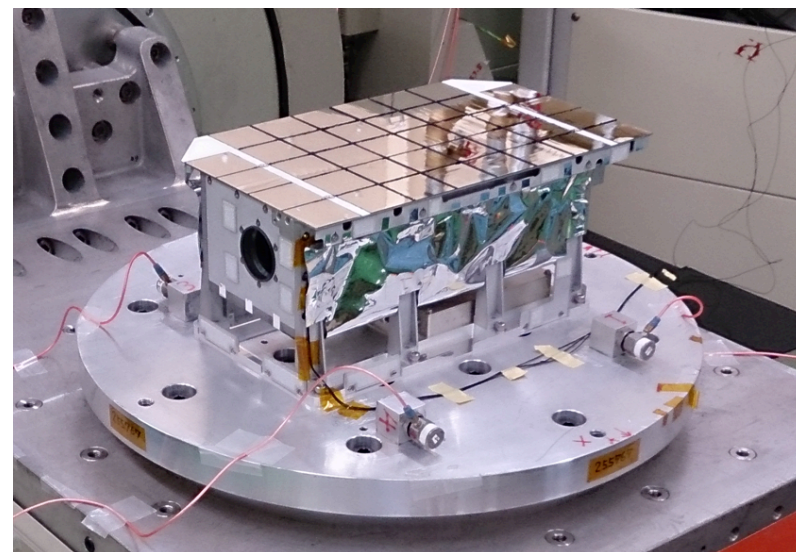

- Observation wavelength range: 1.8–3.2 μm
- Wavelength resolution: 20 nm
- Full field of view: 0.1 deg
- Spatial resolution: 35 m (20-km alt.)
2 m (1-km alt.)
- Detector temperature: –85 to –70 °C
- S/N ratio: 50+ (wavelength 2.6 μm)

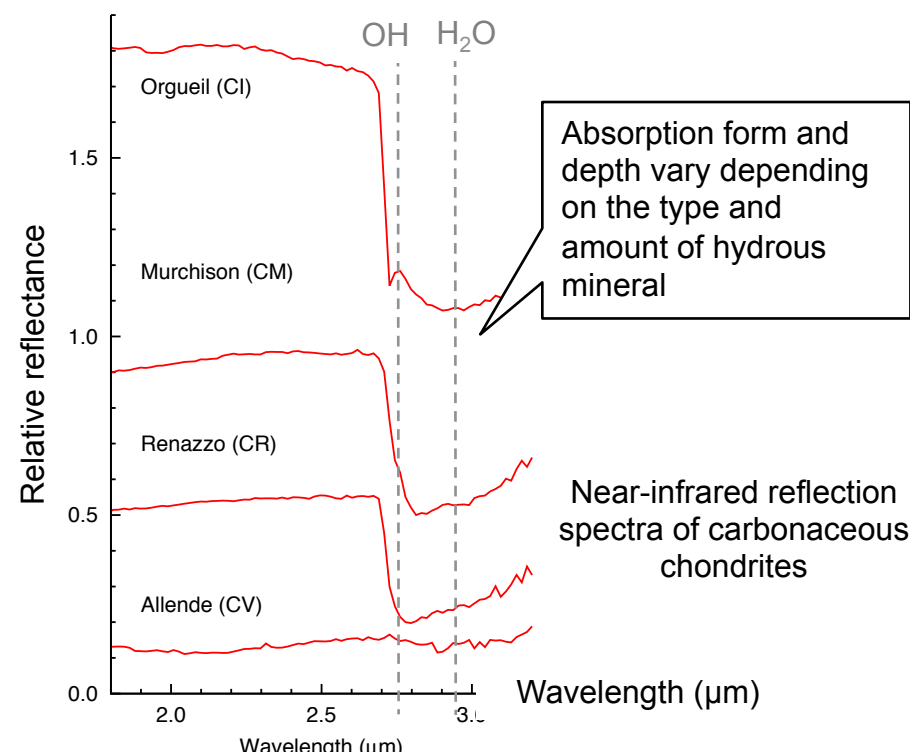



Thermal infrared camera (TIR)



TIR=Thermal Infrared Imager

The surface temperature of the asteroid changes over the day, rising in sunlight and decreasing at night.

Diurnal change in surface temperature is large in fine soils like sand and highly porous rock, and small in dense rock.

We will examine the physical state of the asteroid's surface by 2D imaging (thermography) of thermal radiation from the asteroid.

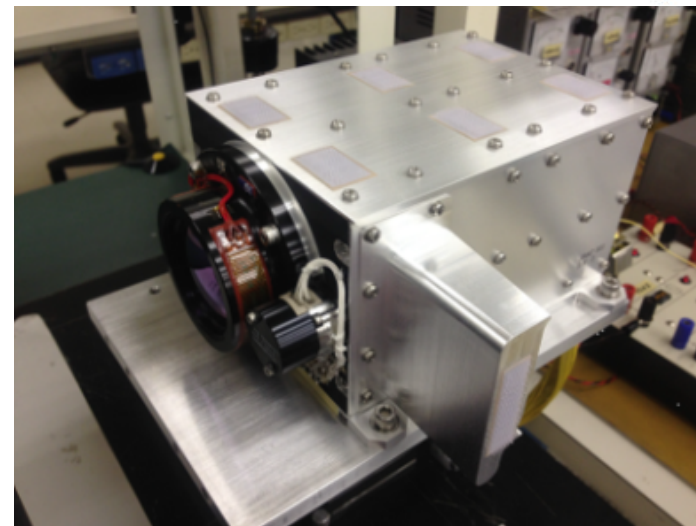

• Detector	: 2D uncooled bolometer
• Observation wavelength	: 8–12 μm
• Observed temperatures	: -40 to 150 $^{\circ}\text{C}$
• Relative accuracy	: 0.3 $^{\circ}\text{C}$
• Dimensions	: 328 × 248 (effective)
• Viewing angle	: 16 $^{\circ}$ ×12 $^{\circ}$
• Resolution	: 20 m (20-km alt.) 5 cm (50-m alt.)

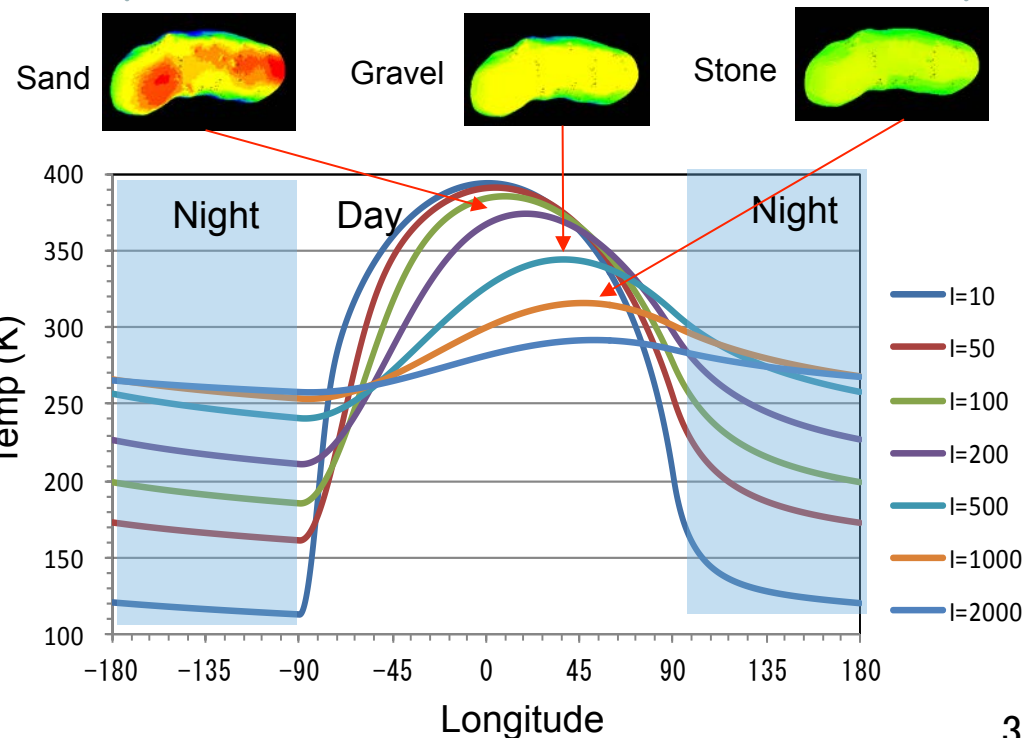
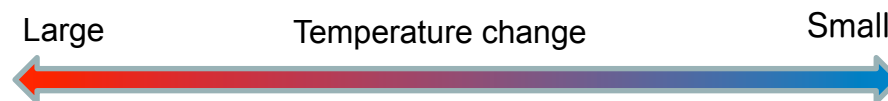



Sampler (SMP)



- Device for acquiring samples from the asteroid surface
- The basic design is the same as that for Hayabusa. As soon as the tip of the cylindrical horn touches the asteroid surface, a small projectile is shot from within the horn and rising surface ejecta are caught in a catcher in the upper part of the horn.
- Sealing performance is improved in Hayabusa2; a newly developed metal seal system ensures that volatile gases can be brought back securely. Noble gases can also be collected.
- The sample catcher has been improved over that onboard Hayabusa, and now contains three chambers instead of two.
- As a further improvement in Hayabusa2, there are small folded parts on the tip of the horn, as shown in the figure. Grains of 1–5 mm are caught in these folds, and the catcher is designed so that samples continue rising when the spacecraft suddenly ceases its ascent, thereby entering the catcher. This provides a backup for sampling by projectile.

Sampler horn

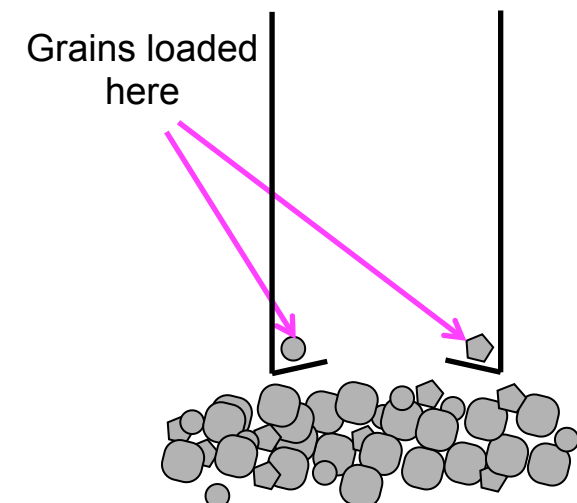



Impactor (SCI)



SCI: Small Carry-on Impactor

■ Objective:

- We will investigate the internal structure of the asteroid through surface changes before and after projectile impact. We will also conduct remote observations of the exposed subsurface material to investigate physical properties of the surface.
- We also perform sampling from craters formed by projectiles, collect “fresh” substances from beneath the surface, and investigate differences from surface materials.
- We will perform “space impact experiments” on actual asteroids to obtain data necessary for celestial collision science.

■ Crater creation: Impact with a high-speed projectile

- Can be performed with a mounted small, lightweight device.
- Results in less soil contamination than methods using explosives to expose asteroid surface materials.
- Impacting projectiles are made from pure copper so that they can easily be distinguished from substances present in asteroids.

■ SCI technology

- Application of technologies for molding explosive charges
- Accelerates a 2 kg copper liner to approximately 2 km/s within approximately 1 ms

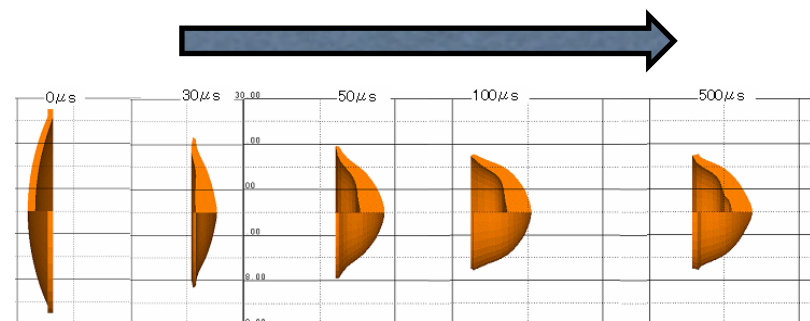

Copper plate (liner) deforms during flight



Impactor: Structure

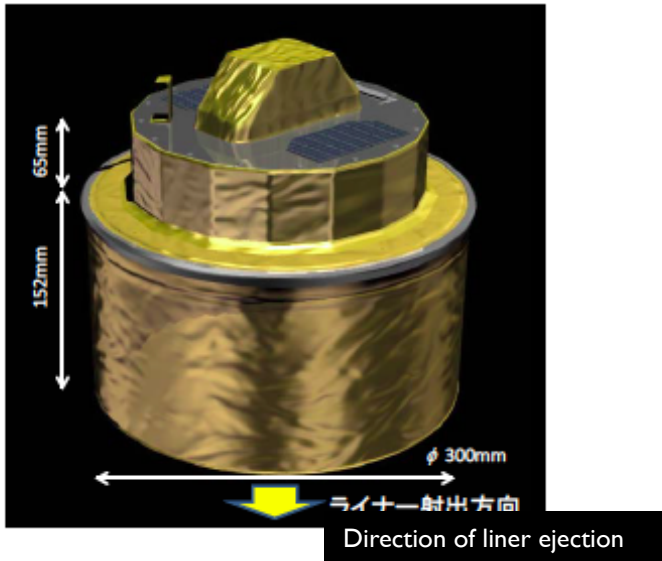

External appearance

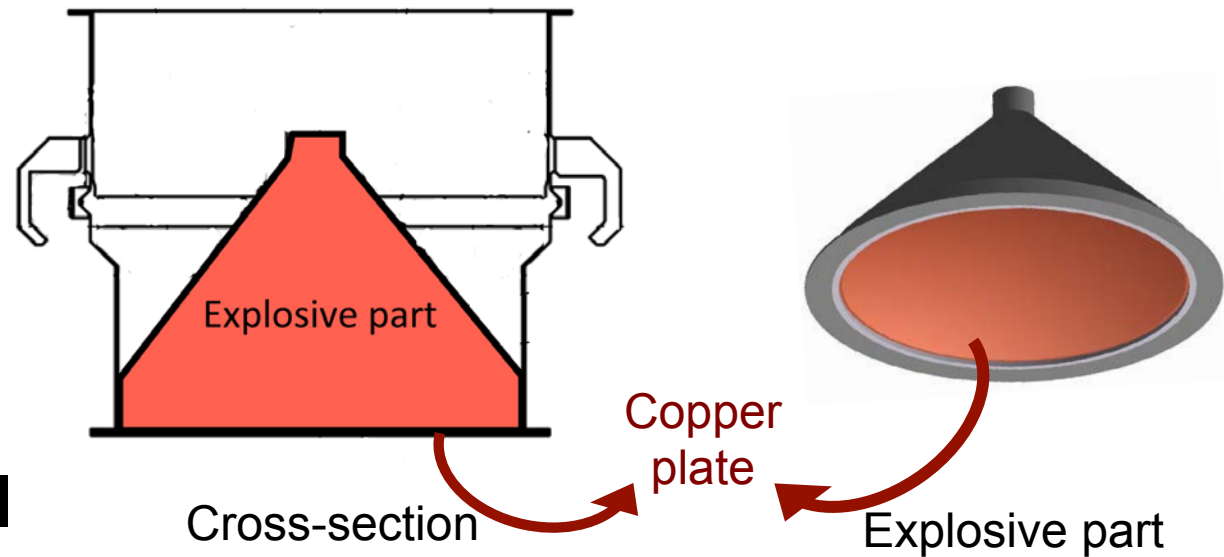

Accelerates the metal liner part (explosives attached to metal casing)

- ◆ Form: Cylindrical (diameter 265 mm)
- ◆ Liner (becomes projectile): Pure copper
- ◆ Explosive: HMX-type PBX (plastic bonded explosive)
- ◆ Mass: Approx. 9.5 kg (explosive: 4.7kg, liner: 2.5 kg)
- ◆ Liner thickness: Approx. 5 mm

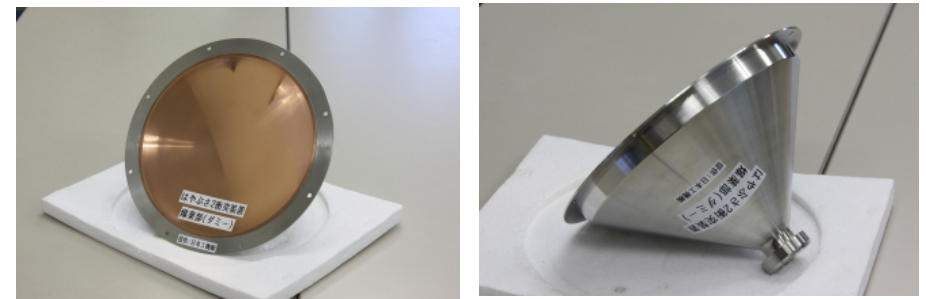

Prototype

(© JAXA)



Impactor testing



Tests: We performed actual-use tests of the impactor to obtain technical data related to the projectile's speed, form, and attitude (17–27 Oct 2011).

Results: We obtained data from half- and full-scale models, which confirmed that the projectile forms a bell shape in the explosive propulsion, rather than disintegrating.

Testing scene: Testing with a full-scale model.

① Testing scene (moment of detonation)

The ignition point is surrounded by a 3-m concrete wall (right), with the projectile fired to the lower left.



③ Pierced targets

Targets pierced by the projectile. The interim targets trace the path the projectile took to the final 4 x 4 m target, 100 m from the impactor.



② Projectile form

The projectile travelling at approximately 2 km/sec. The outer diameter is approximately 135 mm, and the mass is approximately 2 kg. It takes a bell-like form.



④ Moment of impact

The moment of impact into a dirt target approximately 100 m from the firing position. (This is the rear view of the target in image 3).





Deployable camera (DCAM3)

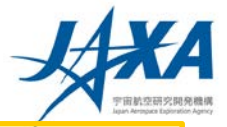

DCAM3 = Deployable Camera 3

Successor to DCAM 1 and 2, mounted on the solar sail IKAROS.

This is a deployable camera for imaging the Small Carry-on Impactor (SCI) and the asteroid as the projectile from the SCI hits the surface, during which time the spacecraft will be sheltering in a safe zone. Imaging data are wirelessly transmitted to the spacecraft in real time.

■ Engineering objective: Confirmation of impactor operations

- The spacecraft will be sheltering in a safe zone before SCI operation, and therefore has no way of confirming successful operations. SCI operations are thus confirmed by releasing a deployable camera before the spacecraft takes shelter and wirelessly transmitting acquired image data.

■ Scientific objective: On-site impact observation

- Continuous imaging of ejecta discharge will clarify relations between asteroid surface conditions and ejecta emission phenomena.
- We aim to identify the ignition point and the impact point of the impactor.
- The produced ejecta will clarify crater formation processes on the asteroid.

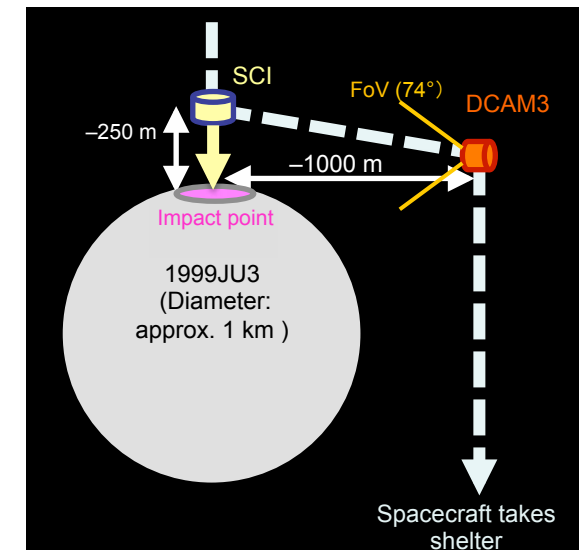
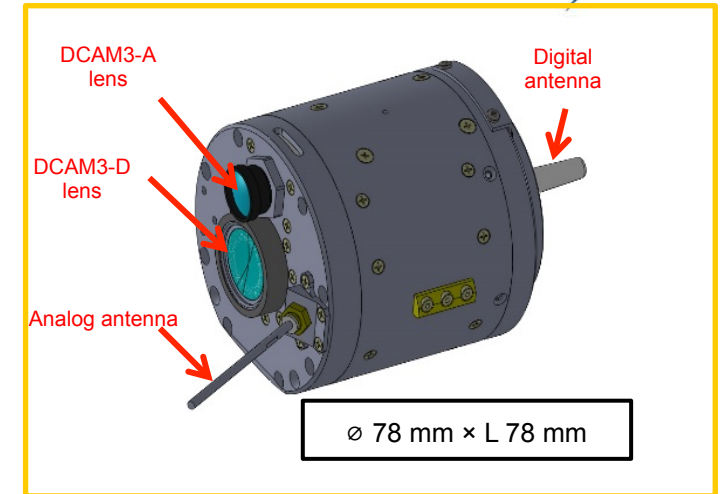

- While taking shelter, the spacecraft deploys the camera at a position allowing views of the impact point from the side.
- The camera is separated so that its optical axis faces the asteroid, and its mechanism separates while rotating about the optical axis to stabilize its attitude.



Deployable camera (DCAM3)



- Overview of specifications and operational plans
- Excluding lenses and the antenna, the separable camera is a $\varnothing 78 \text{ mm} \times \text{H } 81 \text{ mm}$ cylinder.
- Two cameras are mounted: an analog camera that has low resolution but is capable of sending images in real time, and a digital camera for digitally transmitting high-resolution images.
- The image transmitter and the transmission antenna are equipped with both analog and digital systems.
- Batteries have relatively large capacities, allowing for imaging and wireless data transmission of up to 3 h (depending on conditions).
- Image transmission is possible from up to 10 km from the spacecraft.

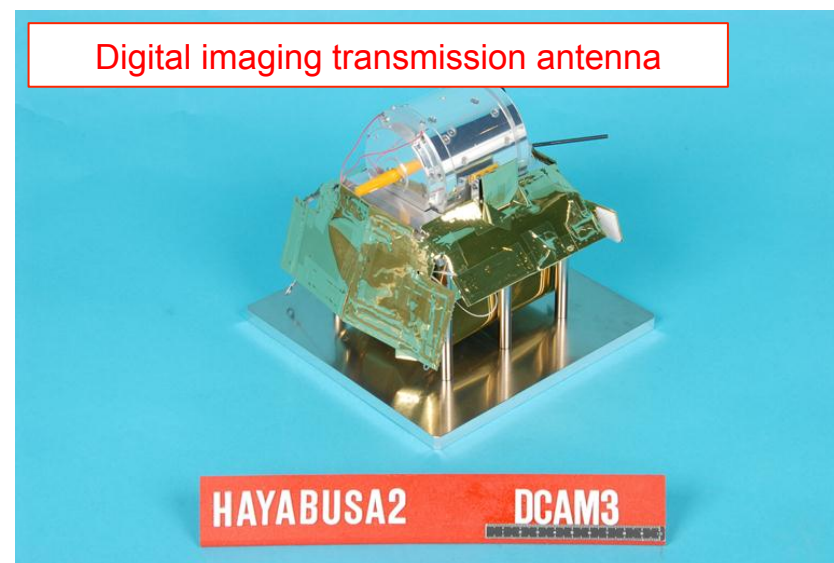
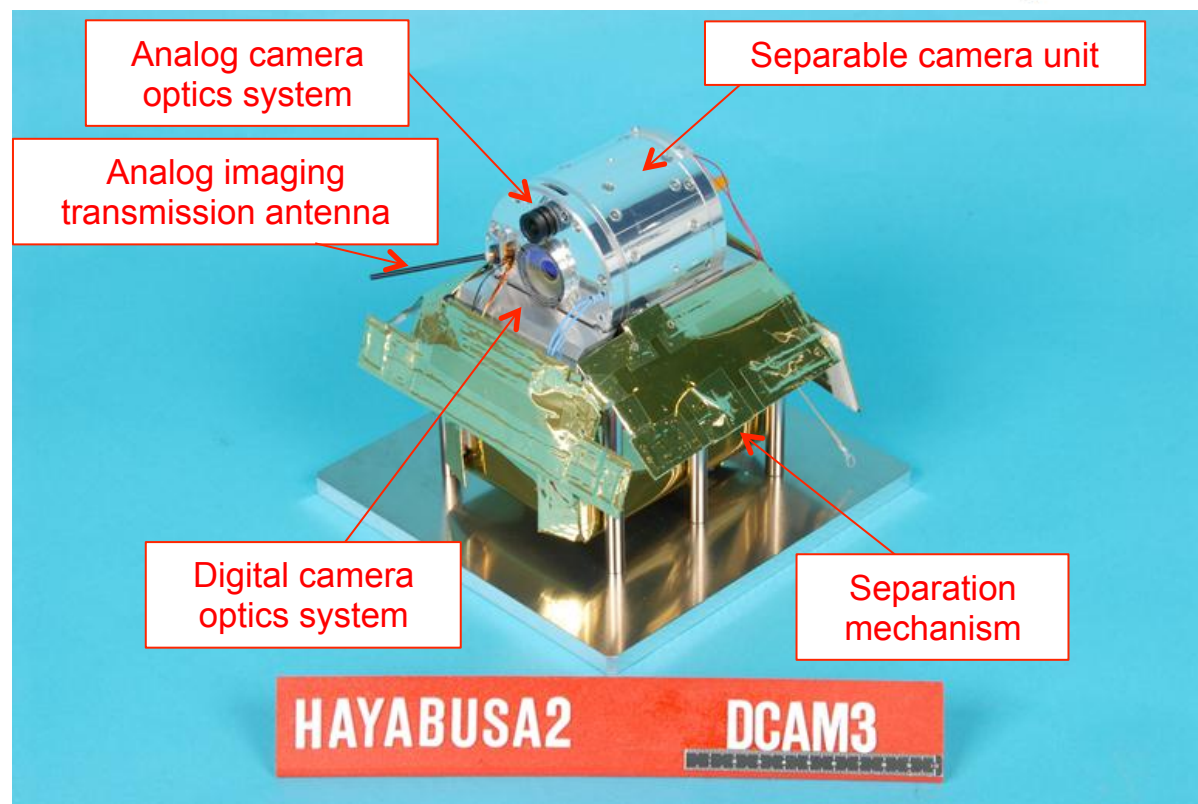



MINERVA-II



- Three robots will travel across and explore the asteroid surface.
- MINERVA-II-1 was developed by the team that developed MINERVA, which was aboard the first Hayabusa. It comprises two rovers, Rover-1A and Rover-1B.
- MINERVA-II-2, which carries Rover-2, is an optional device developed by a university consortium.

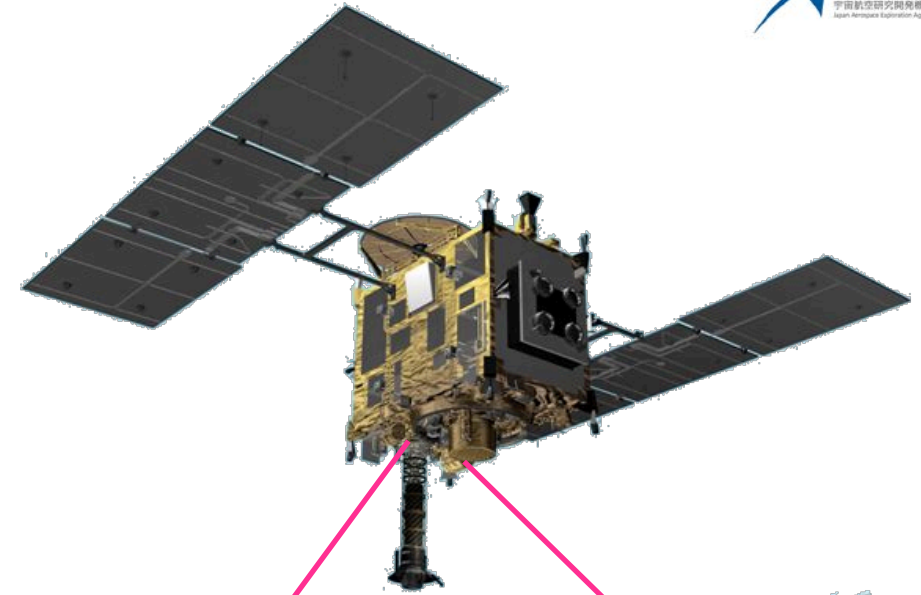

MINERVA-II-2

MINERVA-II-1

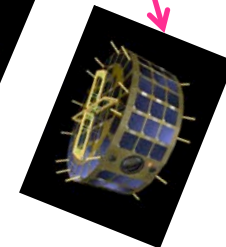
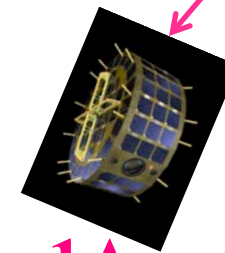
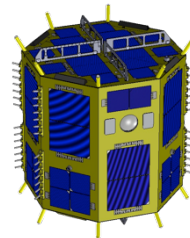
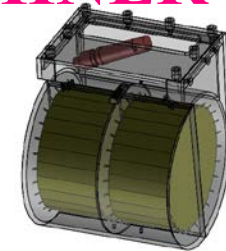
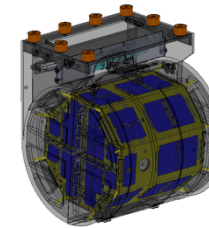

Rover-1A

Rover-1B

Rover-2
(Optional)



MINERVA-II-1



- Successor to MINERVA, which was mounted aboard Hayabusa.
- Purpose: Engineering demonstration of the movement mechanism
- Development: MINERVA-II team (ISAS) with cooperation of the University of Aizu
- MINERVA-II-1 carries two (twin) rovers
- Mass including the deployment structure is 3.3 kg
Dimensions: 22.5 × 22.5 × 20.5 cm
- Rover mass: approx. 1.1 kg
Dimensions: diameter 18 × 7 cm
- Two cameras (wide-angle and stereo)
- Temperature sensor and photodiode
- Accelerometer and gyro
- Explorers move by hopping to explore the asteroid surface

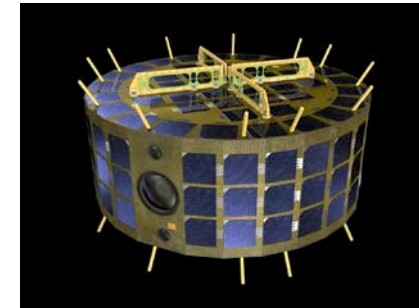
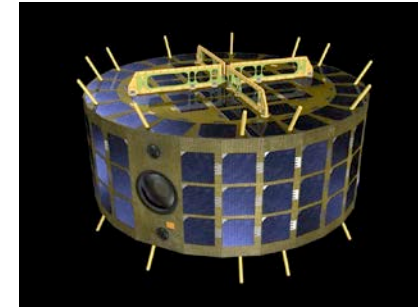



MINERVA-II-2



- Explorer robot developed by a university consortium
This is an optional, piggy-back device
- University consortium led by Tohoku University, co-developed with Tokyo Denki University, Osaka University, Yamagata University, and the Tokyo University of Science
- Total mass including separation mechanism: 1.6 kg
Dimensions: 17.5 × 17.5 × 20.5 cm
- Rover mass: approx. 1 kg
Dimensions: diameter 15 × 16 cm
- Mounted equipment include a camera, thermometer, photodiode, and accelerometer
- Four types of mobility systems are equipped:
 - Environmentally dependent buckling mechanism (Yamagata University)
 - Leaf-spring buckling mechanism (Osaka University)
 - Eccentric motor-type micro-hop mechanism (Tohoku University)
 - Permanent magnet-type impact generation mechanism (Tokyo Denki University)
- The exploration robot hops to move across and explore the asteroid surface.

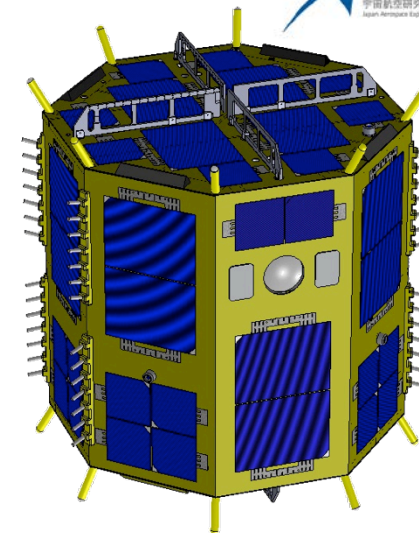



MASCOT



Mobile Asteroid Surface Scout

- Created by DLR (German Aerospace Center) and CNES (French National Centre for Space Studies)
- Small lander with mass approx. 10 kg
- Carries four scientific instruments
- Can move only once, by jumping

Scientific instruments aboard MASCOT

Device	Function
Wide-angle camera (CAM)	Imaging at multiple wavelengths
Spectroscopic microscope (MicrOmega)	Investigation of mineral composition and characteristics
Thermal radiometer (MARA)	Surface temperature measurements
Magnetometer (MAG)	Magnetic field measurements

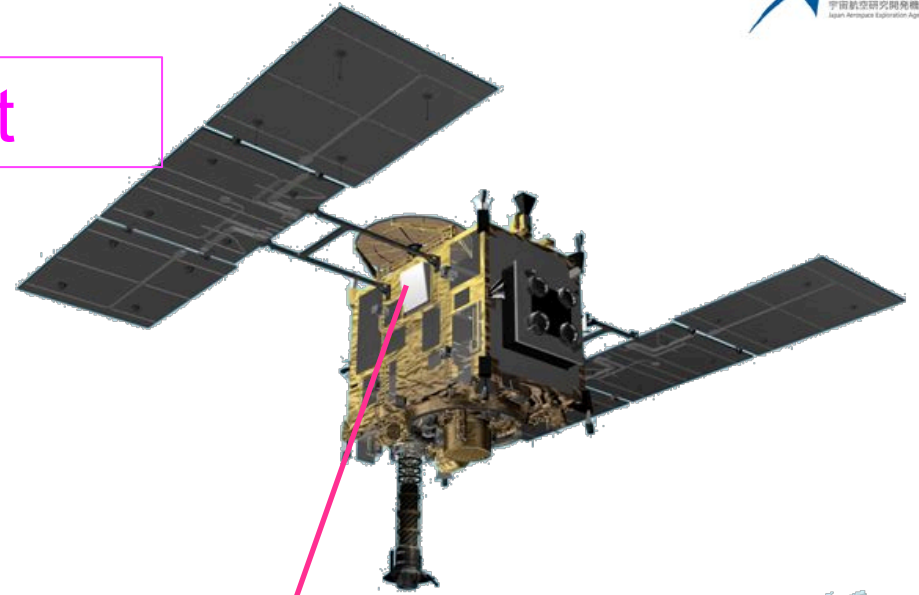

Flight model (© DLR)

MASCOT



Electric propulsion (ion engine)



- Name: $\mu 10$
- Converts xenon* into plasma (ions), which is accelerated by applying voltage.
- A microwave discharge system is used to generate ions.
- Four units are mounted, and simultaneous operation of three generates thrusts of up to 28 mN.
- Approximately 60 kg of loaded xenon fuel, allowing acceleration up to 2 km/s.
- It is used to alter trajectories when cruising from Earth to the asteroid and back.

*Why we use xenon

- Xenon is a monoatomic molecule, so its ionization voltage is smaller than that of gasses comprising two or more atoms. This increases the ratio of added energy that is used for acceleration.
- Reactivity is lower than that of other substances.
- Mass (atomic weight) is large, improving the efficiency of acceleration.



Injection test in a flight model vacuum chamber

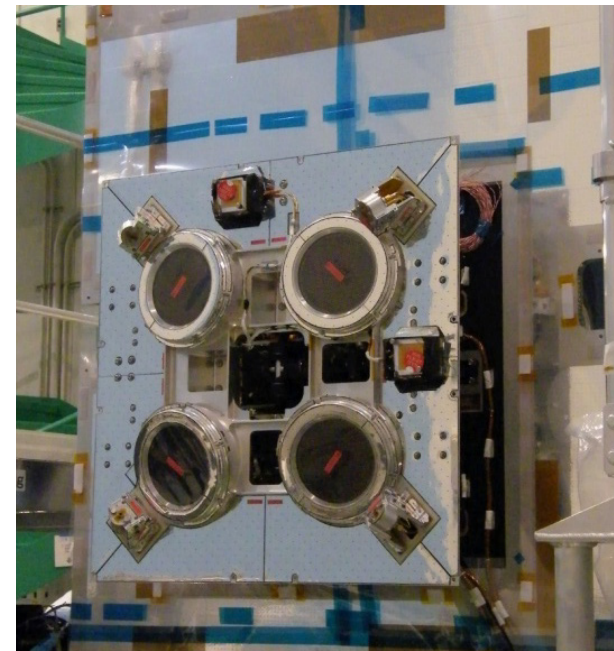

Hayabusa2 ion engine
(© JAXA)



Reference: How ion engines work

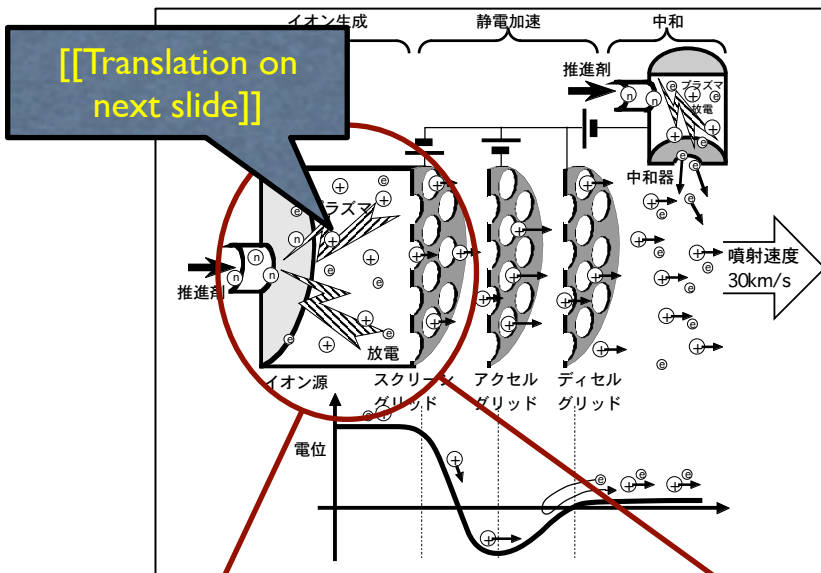

[[Translation on next slide]]

Source: *Dynamic Navigation with Ion Engines (Space Engineering Series 8)*, Corona Publishing (2006)

Different ion generation systems

DC discharge method

Microwave discharge method

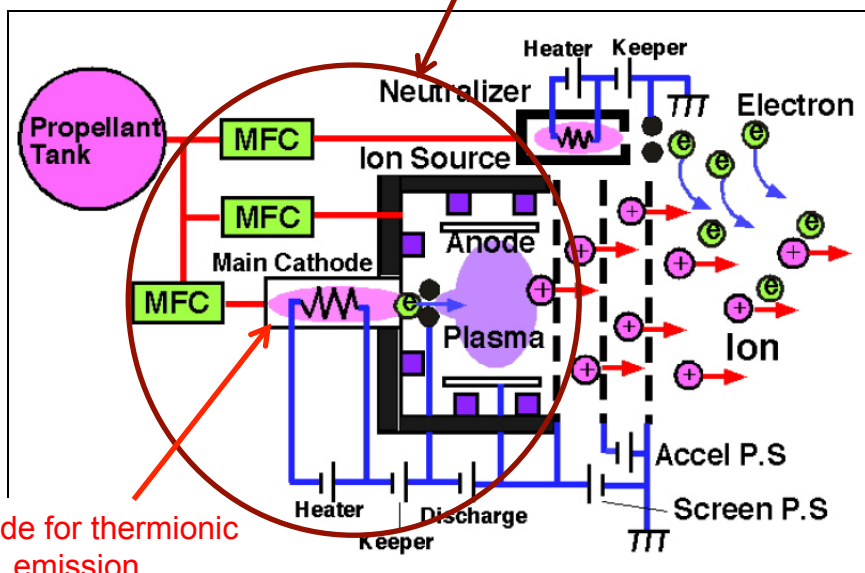

Cathode for thermionic emission

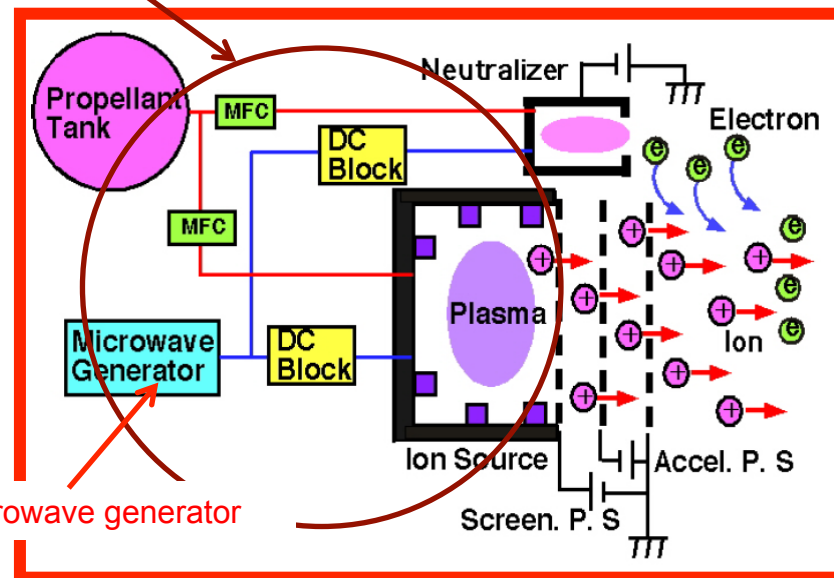

Microwave generator

Note: The ion engine developed in the U.S., the U. K. and the former NASDA was a DC discharge Kaufman-type ion engine or a Ring-Cusped ion engine.

Note: The ion engine developed at the ISAS in Japan is a microwave discharge-type ion engine.

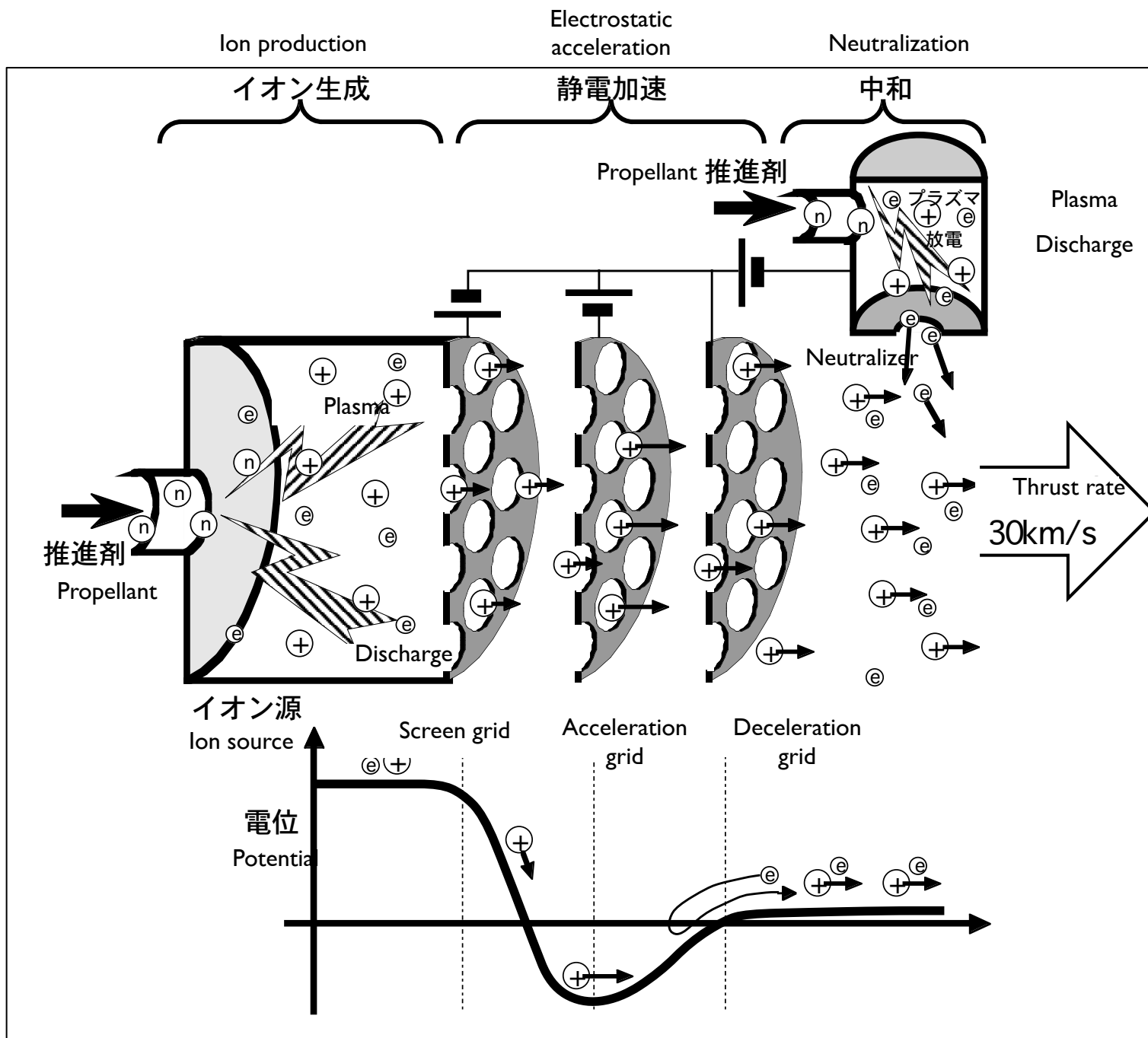



Chemical propulsion system



- The chemical propulsion system is used for attitude control (reaction wheel unloading, safe hold), fine trajectory modifications, and orbital control at the asteroid.
- The thruster is a 20 N two-component system using fuel (hydrazine) and an oxidizer (MON-3).
- There are 12 thrusters in total: 4 on the upper (+Z) surface, 4 on the lower (-Z) surface, 2 on the surface with the ion engine (+X), and two on the surface with the capsule (-X).
- The thruster system has a redundant construction.
- Approximately 48 kg of propellant is carried.

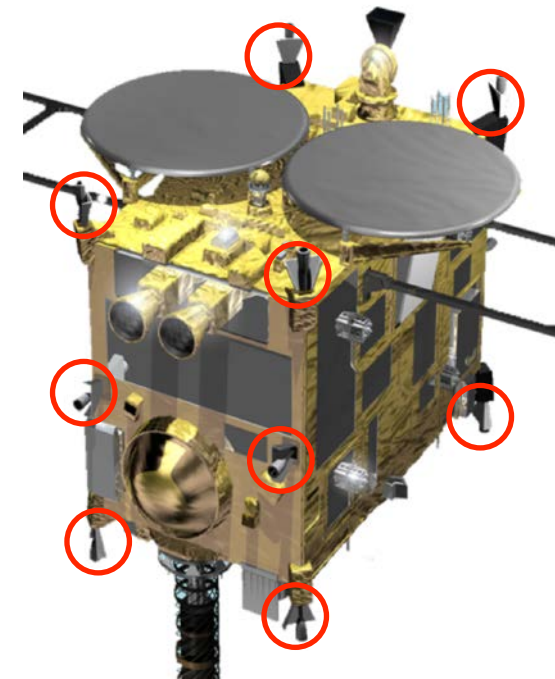

Red circles indicate thruster locations. Not displayed are one thruster on the bottom surface, and one on each of the opposing (ion engine) surfaces between their upper and lower edges, for a total of twelve thrusters.



Chemical propulsion system: Changes from Hayabusa



- Countermeasures against leaks that occurred immediately after Hayabusa touchdown (second time)
 - Improved valve cleaning methods and airtightness tests, fewer welding locations, review of welding procedures, etc.
- Countermeasures against freezing in both pipe systems that occurred after Hayabusa leak
 - Separation of piping routes for the A and B systems and independent heat control
- Countermeasures against orbital insertion failure by the Akatsuki Venus orbiter
 - Full separation of fuel and oxidizer pressure regulating systems
- Measures for realization of the Hayabusa2 impactor mission
 - Confirmation of long-term thrust (collision avoidance) and short-pulse thrust (landing within craters)
- Other changes
 - Metal diaphragm oxidant tank changed to a surface tension device*

*What is a surface tension device?

- This device uses helium gas to apply pressure when extracting oxidant from its tank, ensuring that only oxidant fluid, not helium gas, is extracted. Its naming comes from the fact that it utilizes surface tension of the oxidant.

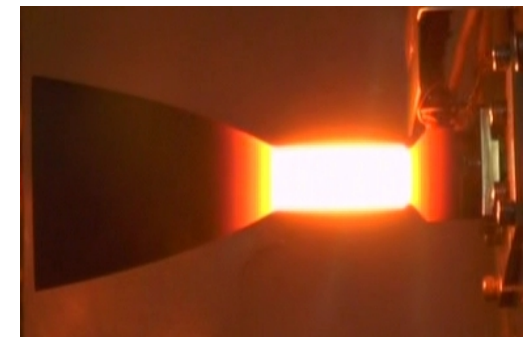

Test burn of a flight model to confirm long-term and short-pulse thrust.



Attitude and orbital control system (AOCS)

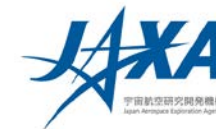

- The AOCS is responsible for attitude control of the probe and navigation near the asteroid.
- Component devices are described below.

① Attitude detection sensor

- Coarse Sun Aspect Sensor (CSAS)
- Star Trackers (STT)
- Inertial Reference Unit (IRU)
- Accelerometer (ACM)

② Asteroid relative position measurement sensor

- Laser altimeter (LIDAR)
- Laser Range Finder (LRF)

③ Image processing component

- Optical Navigation Camera (ONC)
- Digital electronics (ONE-E)

④ Attitude and orbital control

- Reaction Wheel (RW)
- Reaction Control System (RCS)

⑤ Other navigation equipment

- Flashlight (FLA)
- Target Markers (TM)
- Drive (DRV)

AOCU: Attitude and orbit control unit
AOCPP: Attitude and orbit control processor



Target Markers



- Target markers descend to the satellite surface before touchdown as artificial landmarks. The explorer descends while flashing a strobe to recognize the target markers.
- Markers are fashioned like beanbags, with a large number of pellets in a soft enclosure, to prevent the marker from bouncing on the asteroid surface.
- The outer material is highly reflective.
- Hayabusa2 carries five target markers (Hayabusa carried only three).
- Thin sheets with names inscribed are contained within.

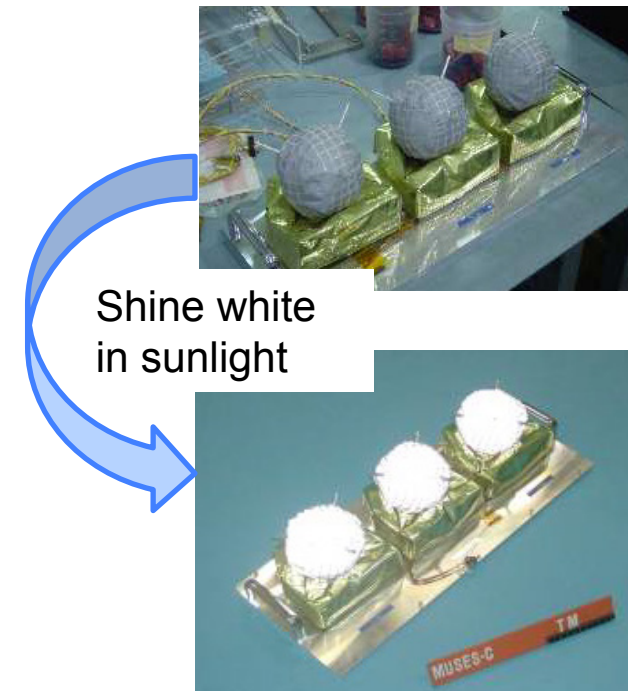
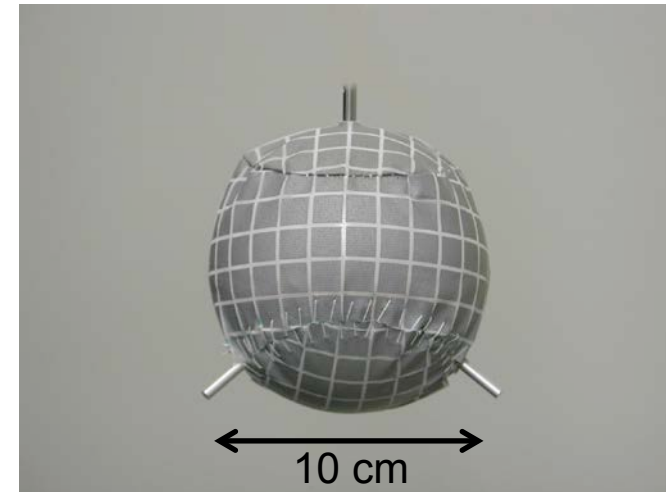



Electrical system



- In sunshine, electric power generated by the solar array paddles is supplied to onboard equipment while the battery is charged. In the shade, the battery stably supplies equipment with power throughout the mission.
- Following the Hayabusa design, this system provides reliability and improved power supply. An outline of primary power supply system equipment is shown below.
 - Solar Array Paddles (SAP)
 - Converts sunlight into electricity for supply to mounted equipment
 - A high-efficiency 3-junction solar cell is used
 - 3-panel × 2-wing construction produces 1460 W @1.42 AU
 - Series-switching regulator (SSR)
 - Stabilizes and controls SAP-generated power for supply to mounted equipment via the PCU
 - Power control unit (PCU)
 - Distributes and controls power from the SSR to mounted equipment
 - Controls and manages power for recharging the BAT
 - Battery (BAT)
 - Provides power through the PCU as needed while in shade, etc.
 - Eleven inline-mounted 13.2 Ah lithium ion batteries

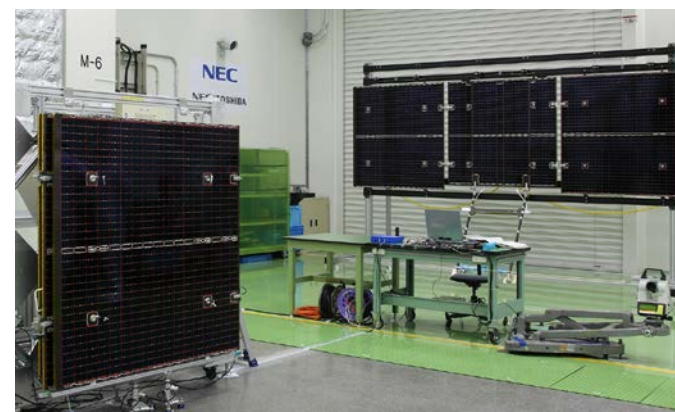

External view of the SAP
(left: stored; right: deployed)

(© JAXA)



Deployment test for SAP deployment

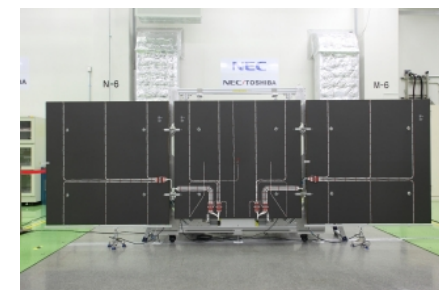
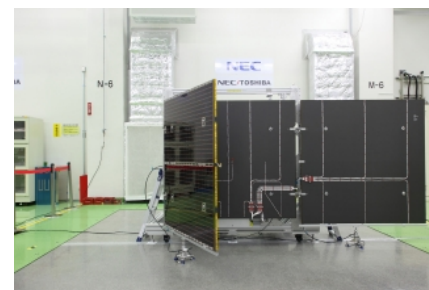
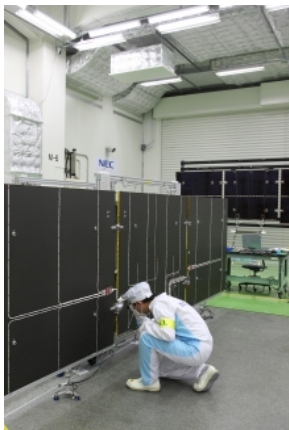
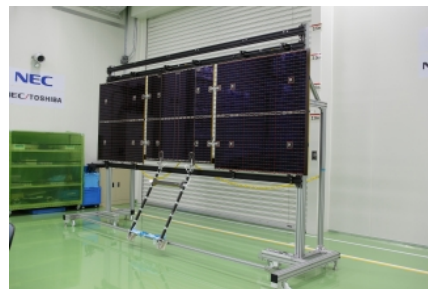
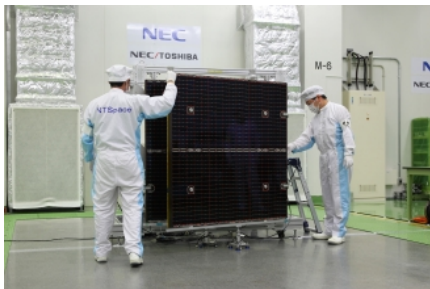
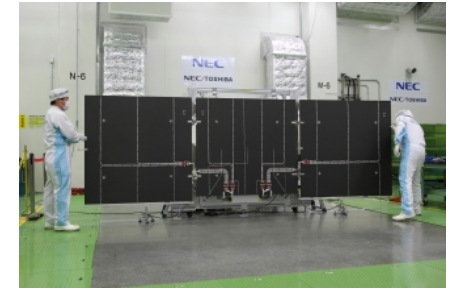

(© JAXA)



Communications (antennas)



- X-band (8 GHz) waves are generally used for communication with ground stations.
- There are three types of X-band antennas: high-, mid-, and low-gain.
- The Ka-band (32 GHz) is used to transmit data from scientific observations to Earth after arrival at the asteroid.
- Approximately four times more data can be transmitted via the Ka-band than by the X-band. However, transmissions are highly affected by weather (attenuation due to rain is high).
- Bit rates are 8 bps–32 Kbps.

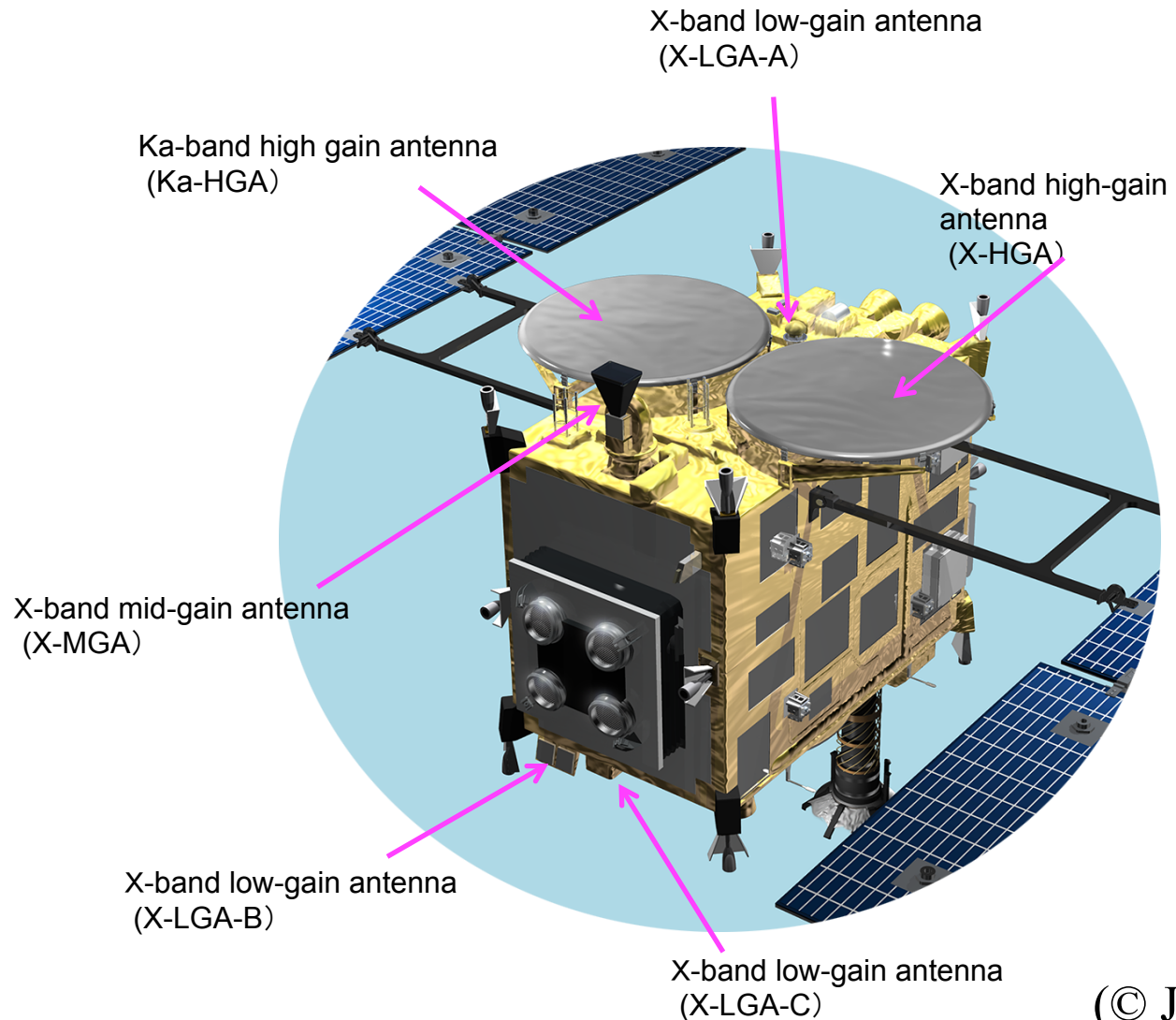

(© JAXA)

What about Ka-band reception?

Ka-band radio waves from planetary explorers currently cannot be received at tracking stations in Japan, so we use overseas tracking stations.



Re-entry capsule



- At the very end of the Hayabusa 2 mission, a capsule carrying a container filled with asteroid samples will re-enter the Earth's atmosphere at 12 km/s and be collected on the ground.
- The capsule separates from the spaceship while spinning at one revolution per 3 seconds. It gets very hot due to atmospheric entry (in technical terms, it passes through a corridor with aerodynamic heating of 14 MW/m²). It opens a parachute at an altitude of about 10 km, allowing it to gently descend and land while outputting a beacon signal for positional search.

- Fundamental design is nearly the same as that in the first Hayabusa, but mounted equipment, parachute deployment trigger (signal), and reliability of associated equipment have been improved.
- The Riparian Environment Management Model (REMM) is newly added, and will measure acceleration, rotation, and internal temperatures during flight.

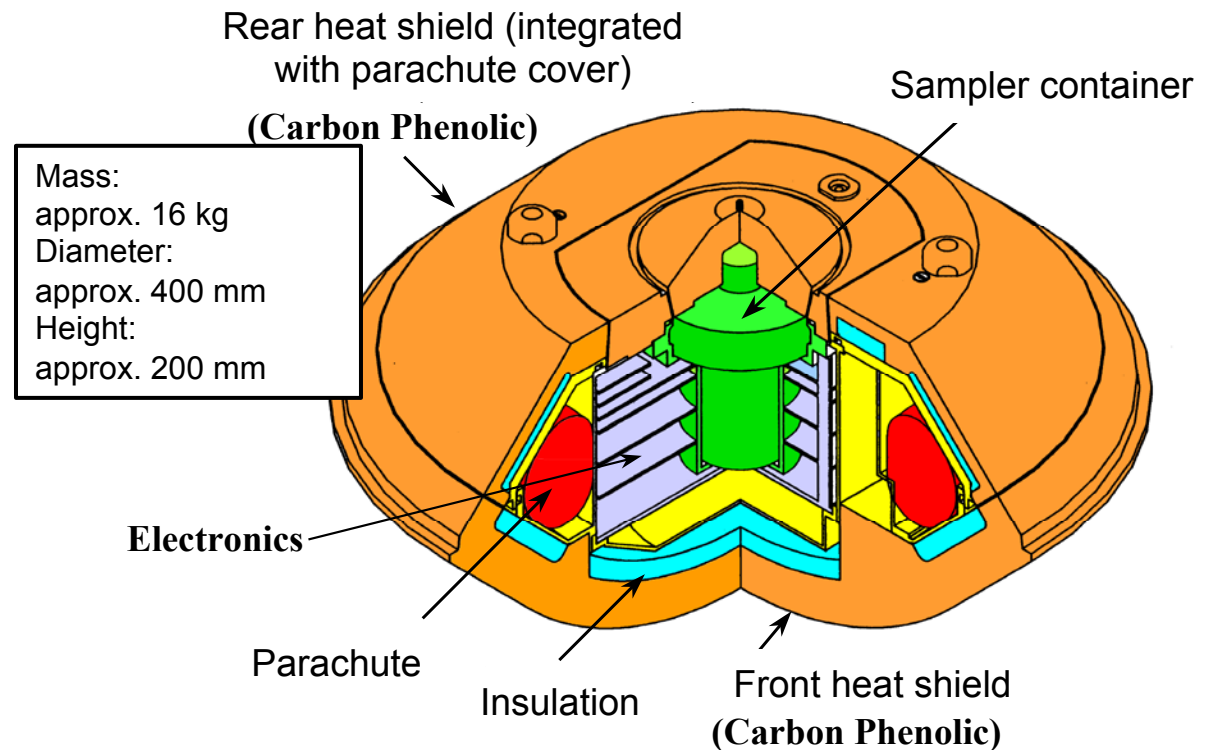



Re-entry capsule

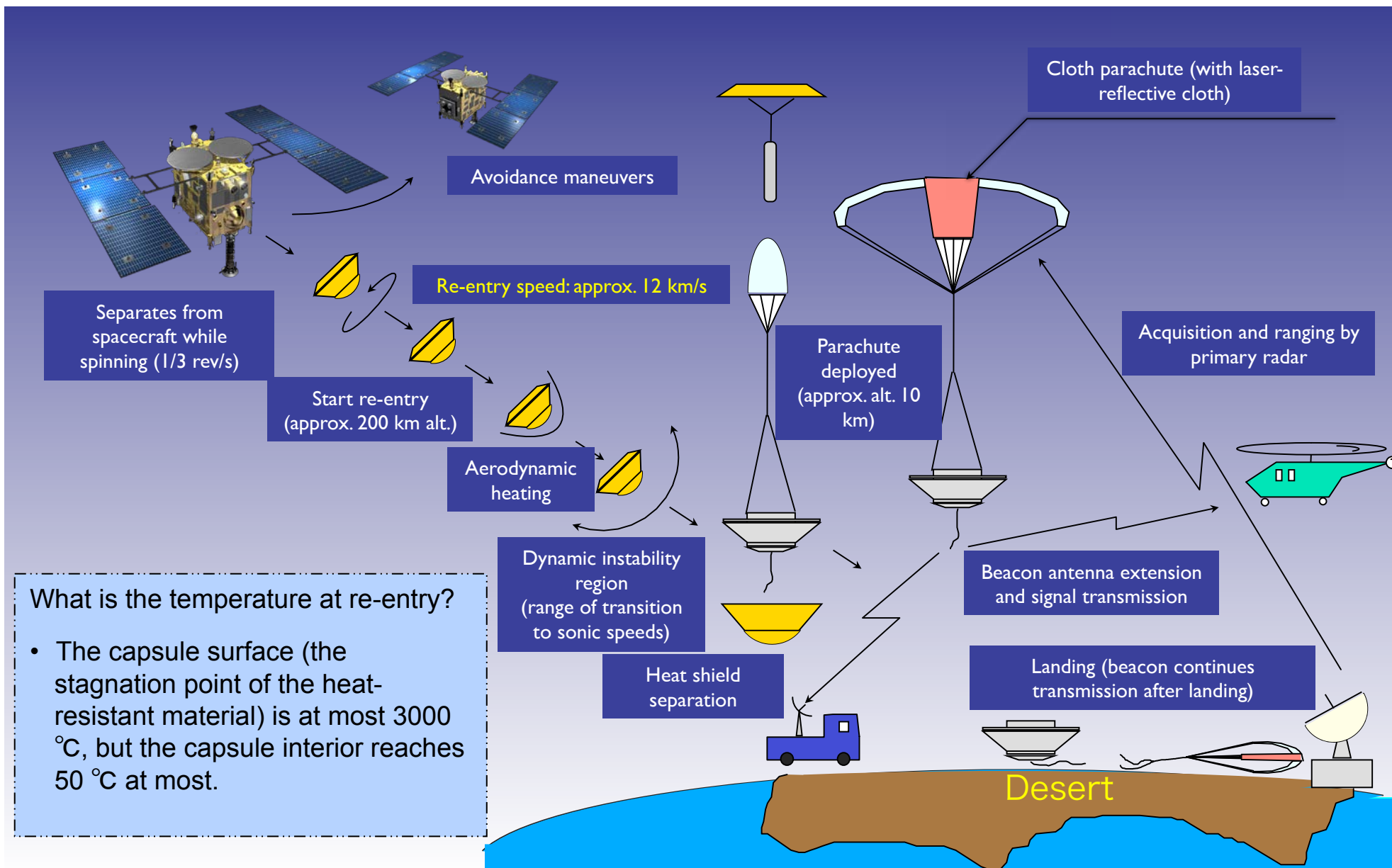

What is the temperature at re-entry?

- The capsule surface (the stagnation point of the heat-resistant material) is at most 3000 °C, but the capsule interior reaches 50 °C at most.

Re-entry sequence overview



Others



Detailed descriptions of the following systems are omitted here:

- Structural system: Overall spacecraft support
- Thermal control system: Manages spacecraft temperatures
- Data processing unit: Processing and control of all data
- Electric instrumentation: Wire-connecting equipment
- Digital Electronics (DE): Processes data from scientific sensors (ONC, TIR, NIRS3, DCAM3)



3. History of the mission



History (overview)



FY2011–2014	: Development phase
3 Dec 2014	: Launch
3–5 Dec 2014	: Critical operations
6 Dec 2014–2 Mar 2015	: Initial function check
Mar 2015–	: Cruising phase
3 Dec 2015	: Earth swing-by
4 Dec 2015–Apr 2016	: Southern hemisphere station operations
22 Mar–21 May 2016	: phase-1 ion engine operation
22 Nov 2016–26 Apr 2017	: phase-2 ion engine operation
10 Jan–3 Jun 2018	: phase-3 ion engine operation
27 Jun 2018	: Asteroid arrival



Launch

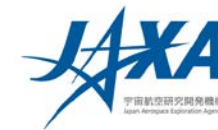

- Rocket: H-IIA-26 (type 202)
- Planned launch date: 30 Nov 2014 (Sun) 13:24:48
←Delayed due to weather
- Actual launch date: 3 Dec 2014 (Wed) 13:22:04
- Possible launch window: 30 Nov–9 Dec 2014
- Launch location: Tanegashima Space Center
- Sub-payloads accompanying launch:
 - Shin'en 2 (Kyushu Institute of Technology)
 - ARTSAT2-DESPATCH (Tama Art University)
 - PROCYON (co-research by University of Tokyo and JAXA)



H-IIA launch Vehicle

- 2-stage liquid-fuel rocket
- Type H2A202

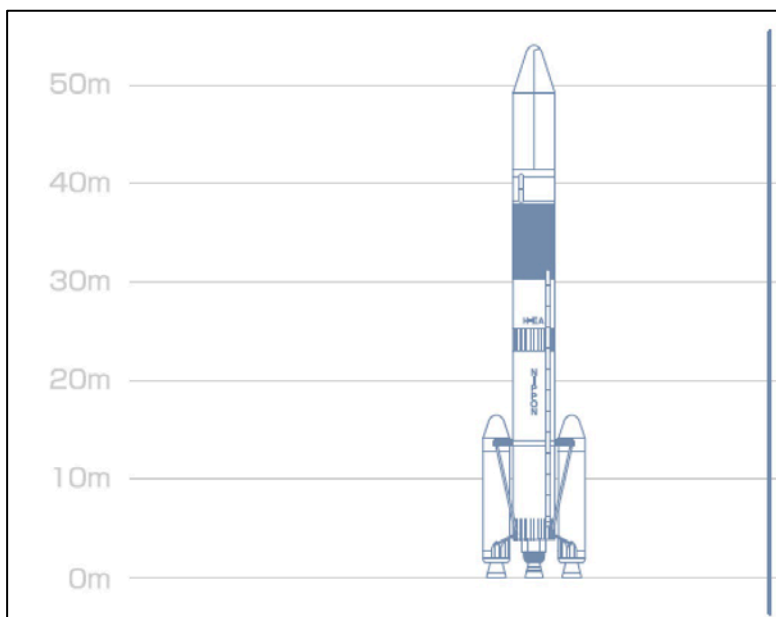

諸元 Item	H2A202 [標準型] [Standard]
全長[m] Length[m]	53
質量[ton]* Mass[ton]*	289
第2段 2nd Stage	1
第1段 1st Stage	1
SRB-A	2
SSB	-

H-IIAの機体名称 H2A a b c (a:1段式/2段式、b:LRBの数、c:SRB-Aの数)

H-IIA naming: H2A a b c (a: 1st/2nd stage; b: number of LRB; c: number of SRB-A)

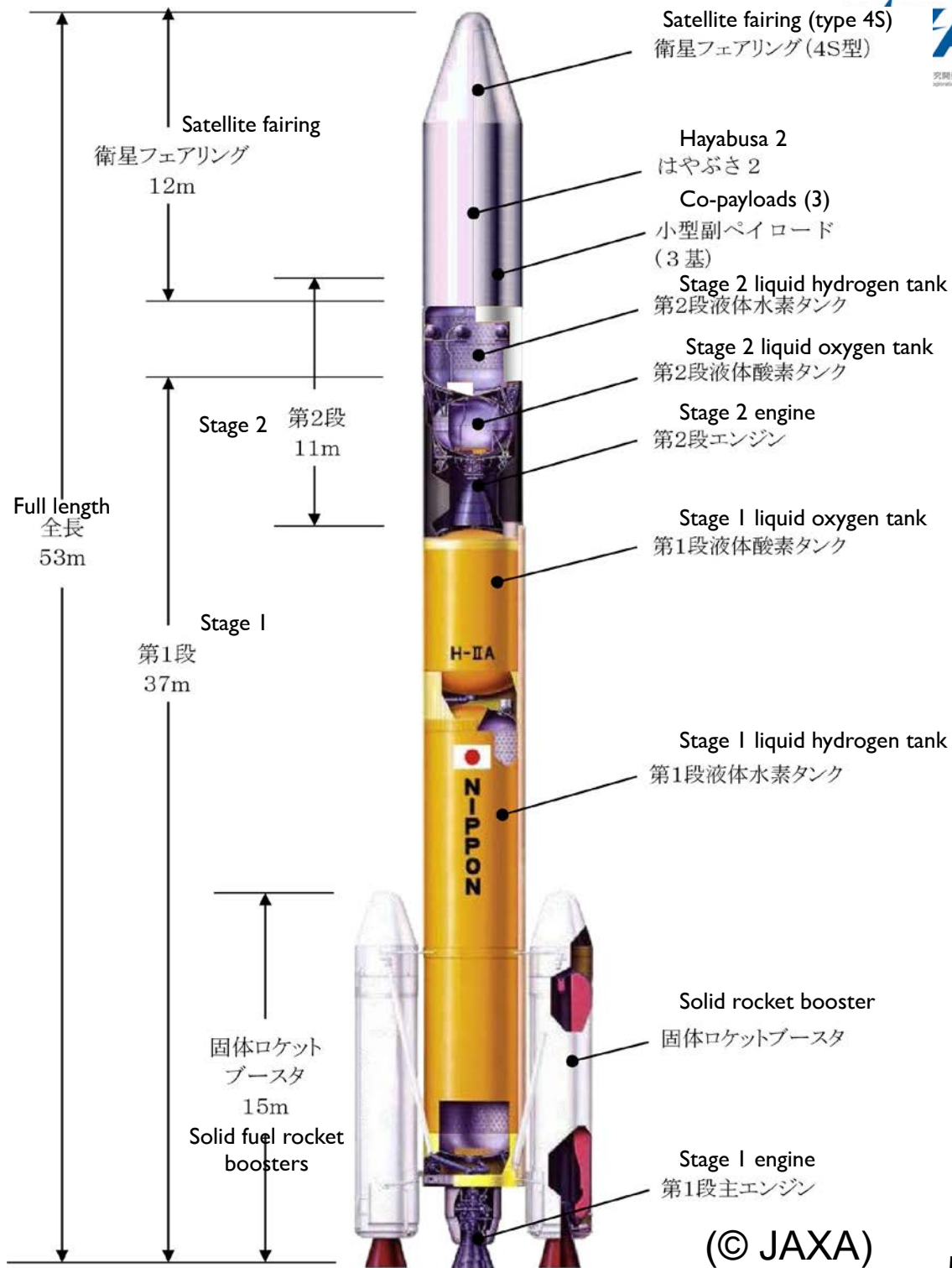

(© JAXA)



Rocket flight plan



Stage	事象	Time after launch			Altitude	Inertial velocity
		Hours	Minutes	Seconds		
		打上げ後経過時間			高度	慣性速度
		時	分	秒	km	km/s
1	1. Liftoff		0	0	0	0.4
2	2. Solid rocket booster burn completes*		1	39	46	1.6
3	3. Solid rocket booster burn separates**		1	48	53	1.6
4	4. Satellite fairing separation		4	10	137	2.8
5	5. Stage 1 engine burn stop (MEC0)		6	36	202	5.6
6	6. Stage 1/2 separation		6	44	207	5.6
7	7. Stage 2 primary engine start (SEIG1)		6	50	210	5.6
8	8. Stage 2 primary engine stop (SEC01)		11	18	254	7.8
9	9. Stage 2 secondary engine start (SEIG2)		11	18	254	7.8
10	10. Stage 2 secondary engine stop (SEC02)		11	18	254	7.8
9	11. Hayabusa 2 separation	1	39	23	250	7.8
10	12. Shin'en 2 separation	1	43	24	313	11.8
11	13. ARTSAT2-DESPATCH separation	1	47	15	889	11.4
12	14. PROCYON separation	1	53	55	2867	10.4
13		1	58	5	4418	9.7
14		2	2	15	6068	9.2

※) 燃焼室圧最大値の2%時点
 ※※) スラスト・ストラット切断

*At burn chamber max. pressure 2%
 **Thrust strut cutoff



Rocket flight route

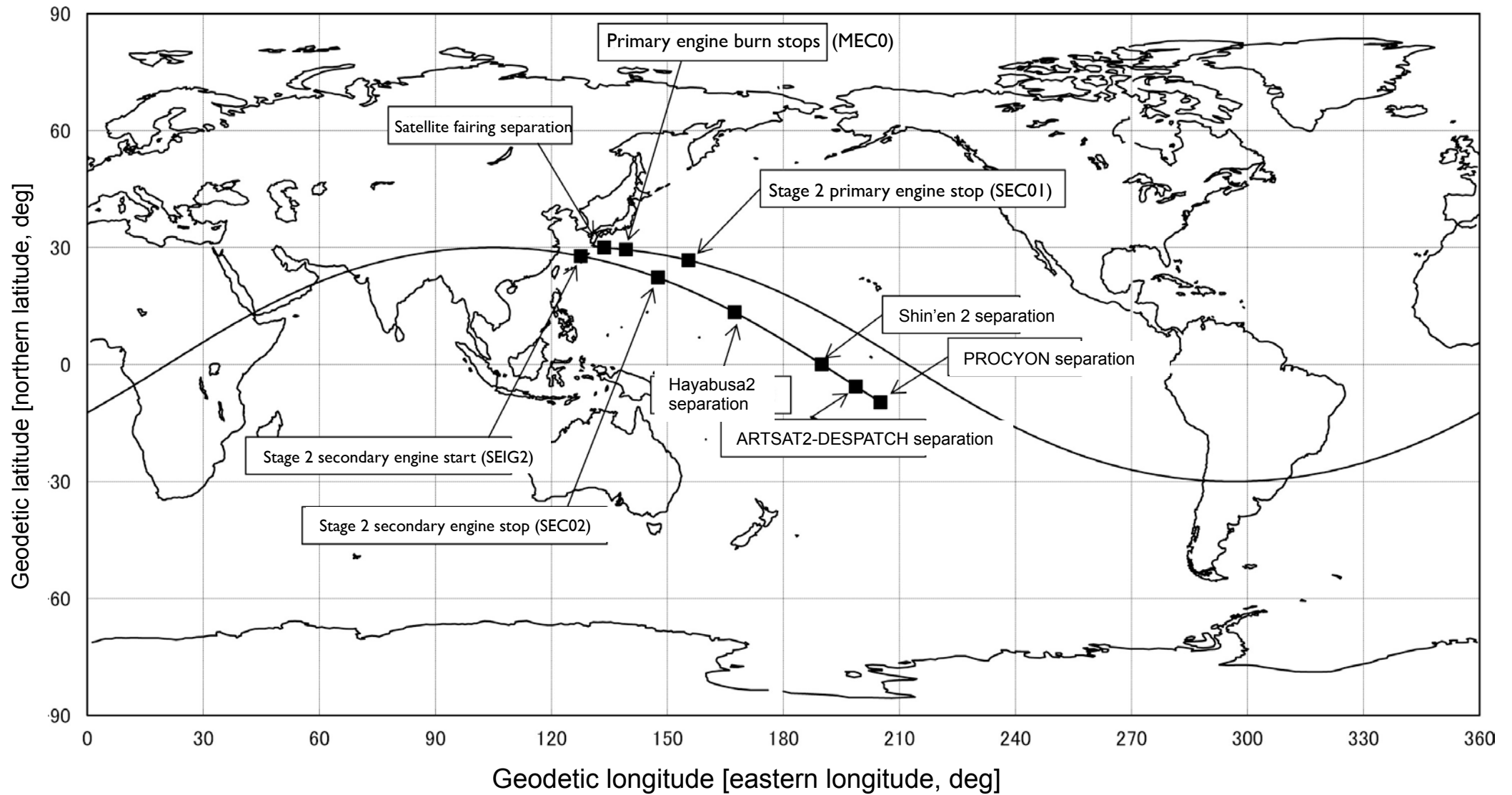



Critical operations (3–5 Dec 2014)

- Solar array panel deployment, sun acquisition control
- Sampling device horn extension
- Release launch lock on the retaining mechanism for the gimbal that controls ion engine direction
- Confirm spacecraft tri-axial attitude control functions
- Ground-based confirmation of functions for precise trajectory determination system

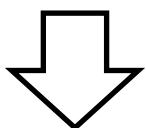

Initial functional confirmation (6 Dec 2014–2 Mar 2015)

- Confirmation of ion engine, communications, power supply, attitude control, observation devices, etc.
- Precise trajectory determination



Initial function check (details)

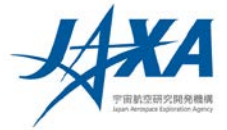

Date		Tasks performed
2014	12/7,8	Functional confirmation of X-band mid-gain antenna beam pattern measurements, acquisition of actual data, and X-band communication equipment
	12/9	Power system (battery) function check
	12/10	Near-infrared spectrometer (NIRS3) inspection
	12/11	Inspection of thermal infrared camera (TIR), deployable camera (DCAM3), Optical Navigation Camera (ONC)
	12/12–15	Function check for attitude and trajectory system (all devices)
	12/16	Inspection of miniature rover (MINERVA-II) and lander (MASOT)
	12/17	Inspection of re-entry capsule and impactor (SCI)
	12/18	5-point pointing test of X-band high-gain antenna (XHGA), pre-operation of ion engine
	12/19–22	Ion engine baking
	12/23–26	Ion engine test operation (ignition) *performed for each engine [12/23: ion engine A; 12/24 ion engine B; 12/25: ion engine C; 12/26: ion engine D]
12/27–1/4	Precise trajectory determination, Delta Differential One-way Ranging (DDOR)	
2015		[No operations on 12/28, 1/1–2]
	1/5–7	Ka-band communications device actual data acquisition, antenna pattern measurements
	1/9–10	Ka-band DSN station DOR, lensing tests
	1/11	Ion engine pre-operations
	1/12–15	Ion engine paired test operations [1/12: A+C; 1/13: C+D; 1/14: A+D; 1/15: A+C]
	1/16	Ion engine tri-set testing: A+C+D
	1/19–20	Paired engine 24-hour continuous autonomous operation: A+D
	1/23	Function check of laser altimeter (LIDAR), laser range-finder (LRF), flash lamp (FLA)
1/20–3/2	Confirming functions such as coordinated operation of multiple devices for transition to cruising phase (regular operations) Function check of linked operations, such as solar light pressure effects evaluation, data acquisition from sun tracking movement behavior, solar light pressure and attitude trajectory control equipment (reaction wheels, etc.), ion engine	



Mar 2015 swingby



2015.03.02	Initial operations phase complete, followed by normal operations phase.
2015.03.03–21	EDVEGA phase-1 IES operation
2015.03.27–05.07	Solar sail mode operations (maintains fuel-free solar orientation using only 1 RW out of 4. Other RWs are kept in the OFF state)
2015.05.12–13	Three IES operate in 24-hour mode (ITR-A+C+D)
2015.06.02–06	EDVEGA phase-2 IES operation
2015.09.06	Solar sail mode operation starts
2015.09.01–02	IES-TCM (precise trajectory control for swing-by)
2015.10.01–12.03	Precise guidance phase (TCM by RCS twice)
2015.12.03	Earth swing-by



After Earth swingby through late 2016



- -2016.04E Southern hemisphere station operations (by DSN Canberra and ESA Malargüe only)
- 2016.03.22 Transfer phase-1 ion engine operations start
- 2016.05.21 Transfer phase-1 ion engine operations end
- 2016.05.24, 06.01–09 Mars observations (–Z Mars orientation)
- 2016.06.14–20 Light pressure confirmation operations
- 2016.06.22–23 DSN–DSN uplink transfer testing
- 2016.06.29–07.03 DSN Ka-band communication testing
- 2016.07.05–08 ESA Ka-band compatibility testing
- 2016.08.03 Transition to attitude control solar sail mode
- 2016.10.08 Transition to 3-axis attitude control wheel
- 2016.10.11–16 STT Mars observations (OPNAV practice)
- 2016.10.19–22 ONC fixed-star observations
- 2016.11.02, 04 DSN–UDSC uplink transfer testing
- 2016.11.22 Transfer phase-2 ion engine operations start



2017–



- 2017.04.18 ONC-T imaging near L_5
- 2017.04.26 Transfer phase-2 ion engine operations end
- 2017.05.16–28 ONC imaging of Jupiter and fixed stars
- 2017.05/30–06.01 RCS autonomous maneuvering tests
- 2017.09.05 Reset internal clock (TI) to zero
- 2017.11.18, 28 DSN–SSOC real-time Doppler transmission testing
- 2017.12.02 DSN–UDSC uplink transfer testing
- 2017.12.26–27 IES test maneuvers
- 2018.01.10 Transfer phase-3 ion engine operations start
- 2018.02.26 First Ryugu observations
- 2018.06.03 Transfer phase-3 ion engine operations end
- 2018.06.03 Asteroid approach navigation start
- 2018.06.27 Asteroid arrival
- :



Summary of ion engine operations

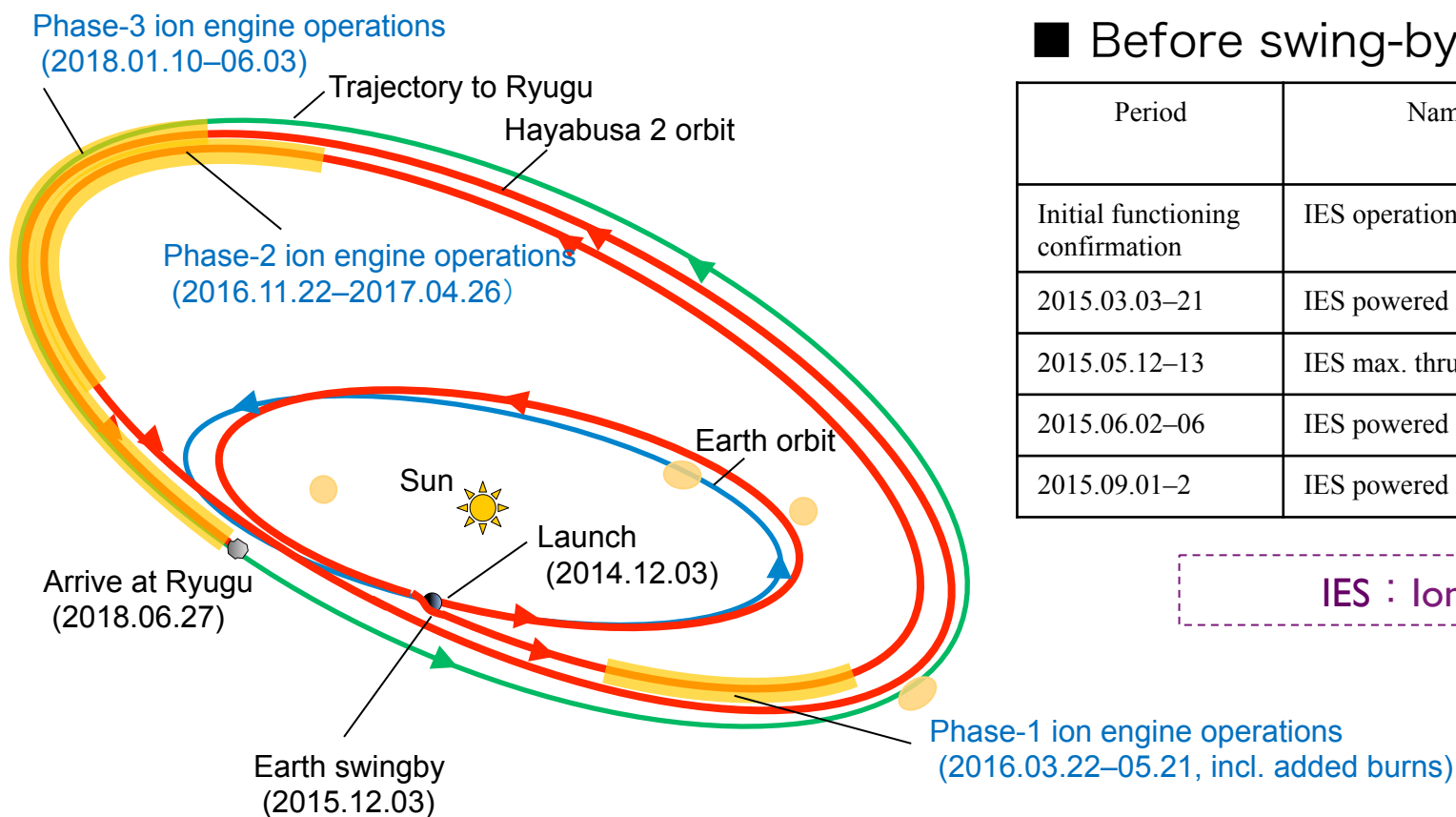

■ Before swing-by

Period	Name	Units	Accel. m/s	Time H
Initial functioning confirmation	IES operations testing	-	-	-
2015.03.03–21	IES powered flight 1	2	44	409
2015.05.12–13	IES max. thrust test	3	4	24
2015.06.02–06	IES powered flight 2	2	11	102
2015.09.01–2	IES powered flight 3	2	1.3	12

IES : Ion Engine System

■ After swing-by

Period	Name	Units	Accel. m/s	Time h
2016.03.22–2016.05.21	Phase-1 ion engine operations	3 (2 at times)	127	798
2016.11.22–2017.04.26	Phase-2 ion engine operations	3 (2 at times)	435	2593
2018.01.10–2018.06.05	Phase-3 ion engine operations	2→3	393	2475



Description of primary operations

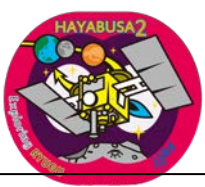

Solar sail mode (2015–)



Attitude control using the power of sunlight

A new technology that requires only a single reaction wheel; no fuel needed

- A new technology for Hayabusa2 that utilizes findings from Hayabusa and IKAROS
- This technology (a type of “solar sail” technology for utilizing the power of sunlight) allows stable control of spacecraft attitude with only one of the four reaction wheels aboard Hayabusa 2 turned ON, others OFF.
- Realizes non-fueled, long-term maintenance of sunward orientation, which was not possible in earlier spacecraft.

←Attitude maintenance realized by this technology for over 9 months of the 2.5-year flight.

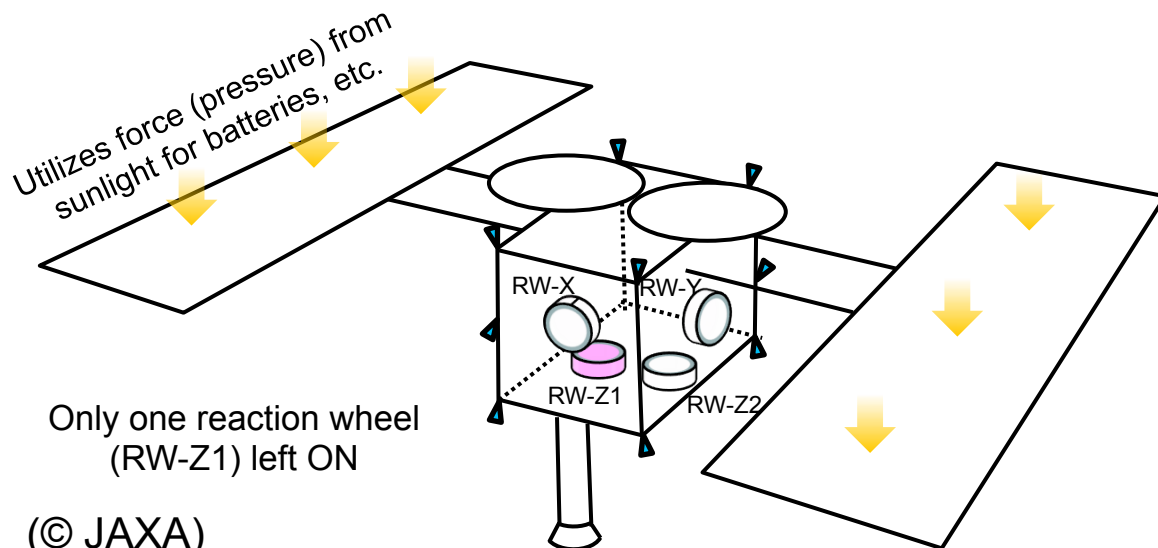

Hayabusa
(2003–2010)

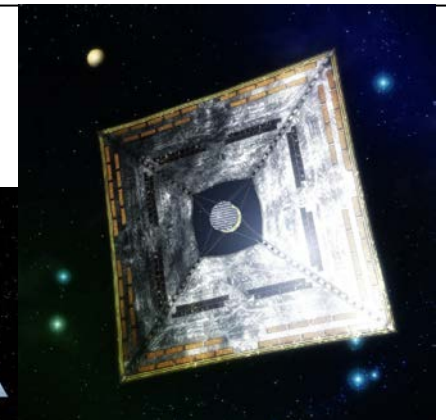

IKAROS
(2010–)



Scientific results from the swing-by (3 Dec 2015)



ONC-T



Color Earth image

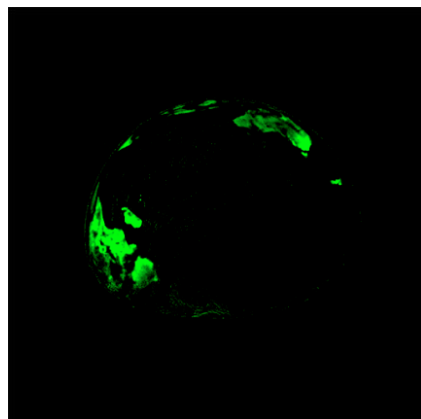

Intensity distribution of light reflected from vegetation

TIR

Australia (warmer than ocean)

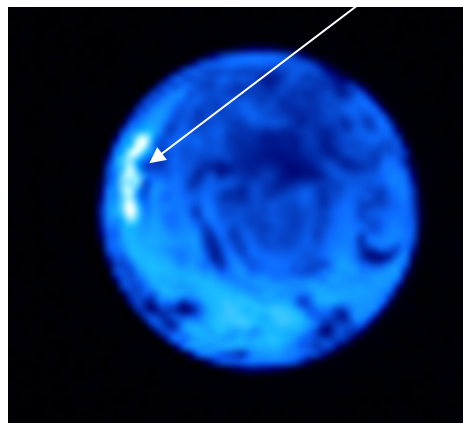

TIR thermal image

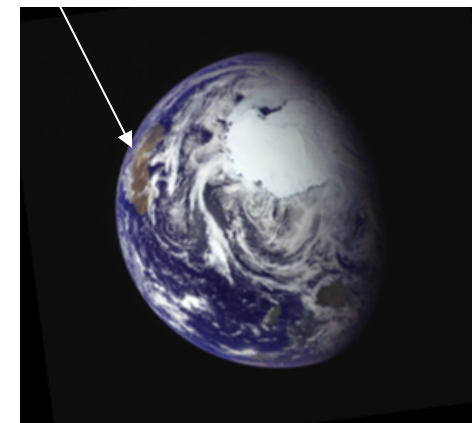

ONC-T color image

NIRS3

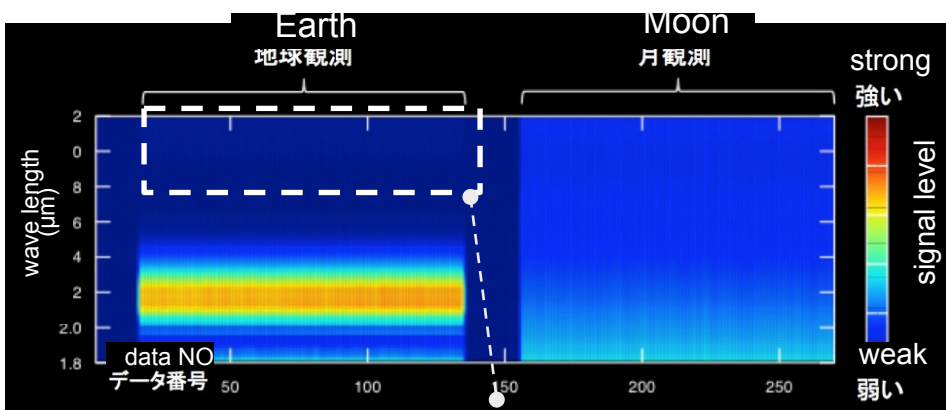

Light absorption by water molecules in Earth's atmosphere

LIDAR

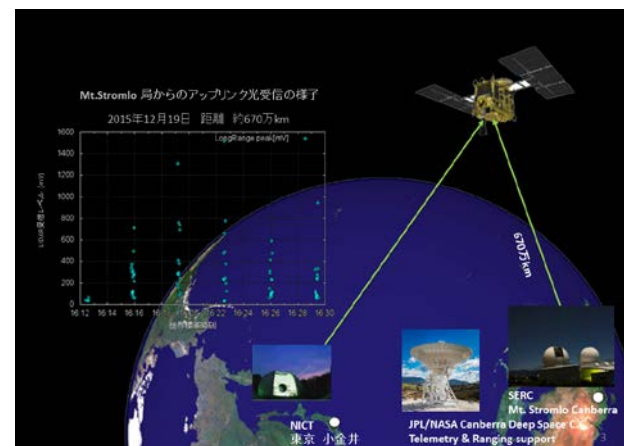

Successful laser reception at 6.7 million km (0.045 AU) on 19 Dec 2015



Mars imaging (May–Jun 2016)



- 24 May, 1–9 Jun 2016
- We performed observations, taking advantage of an alignment of Hayabusa2, Earth, and Mars. (Observations by ONC-T, NIRS3, TIR)

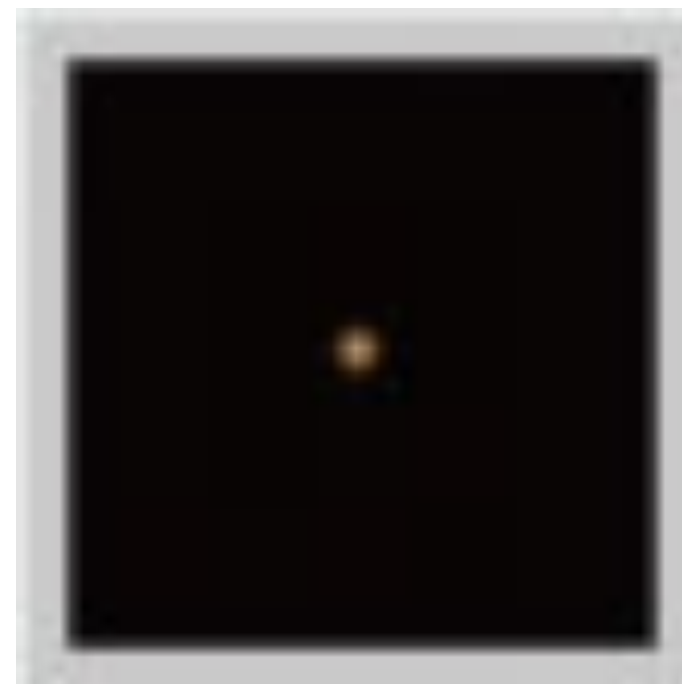
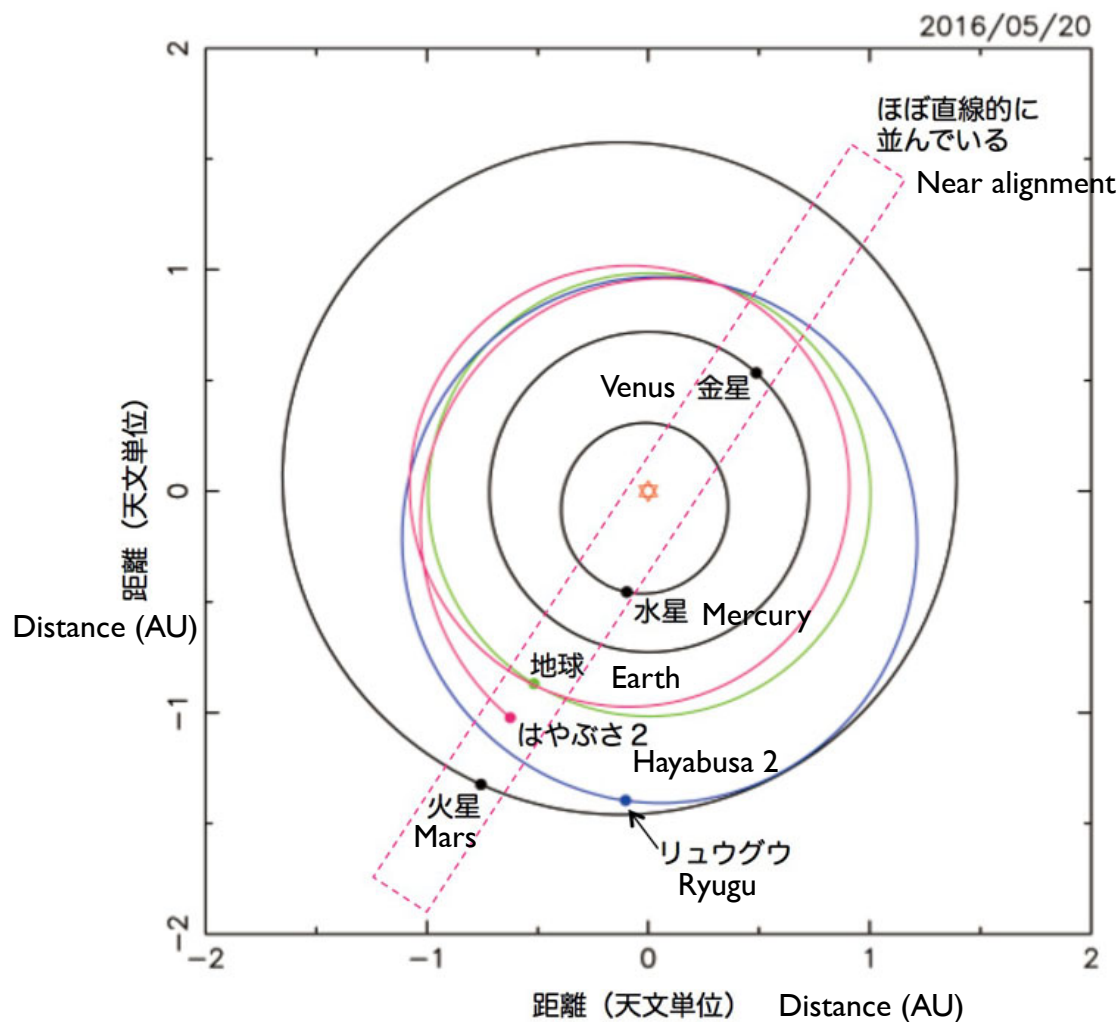

ONC-T image of Mars
21:46 24 May 2016 (Japan time)

(© JAXA)



Uplink transfer (Jun–Nov 2016)

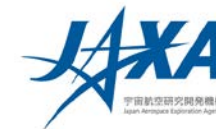

Uplink transfer technology testing: 22–23 Jun 2016 ← between DSN stations

2–4 Nov 2016 ← between Usuda–DSN

Previous method

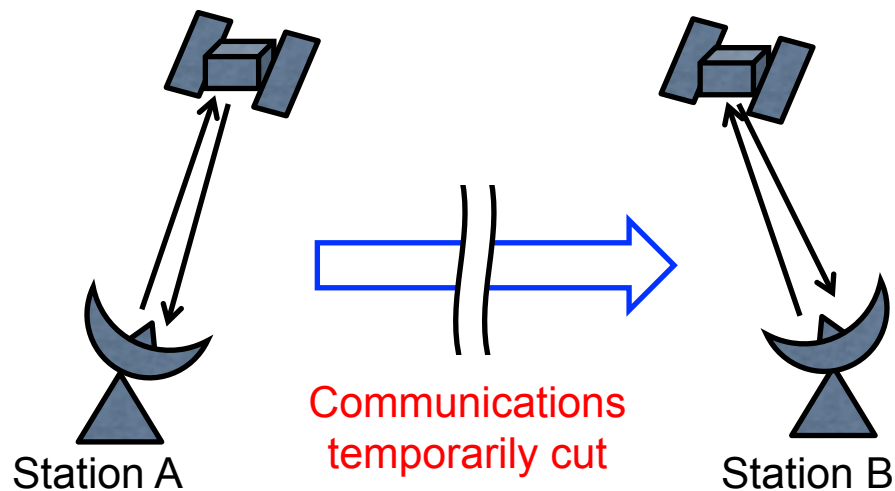

First successful test in Japan!

Uplink transfer:

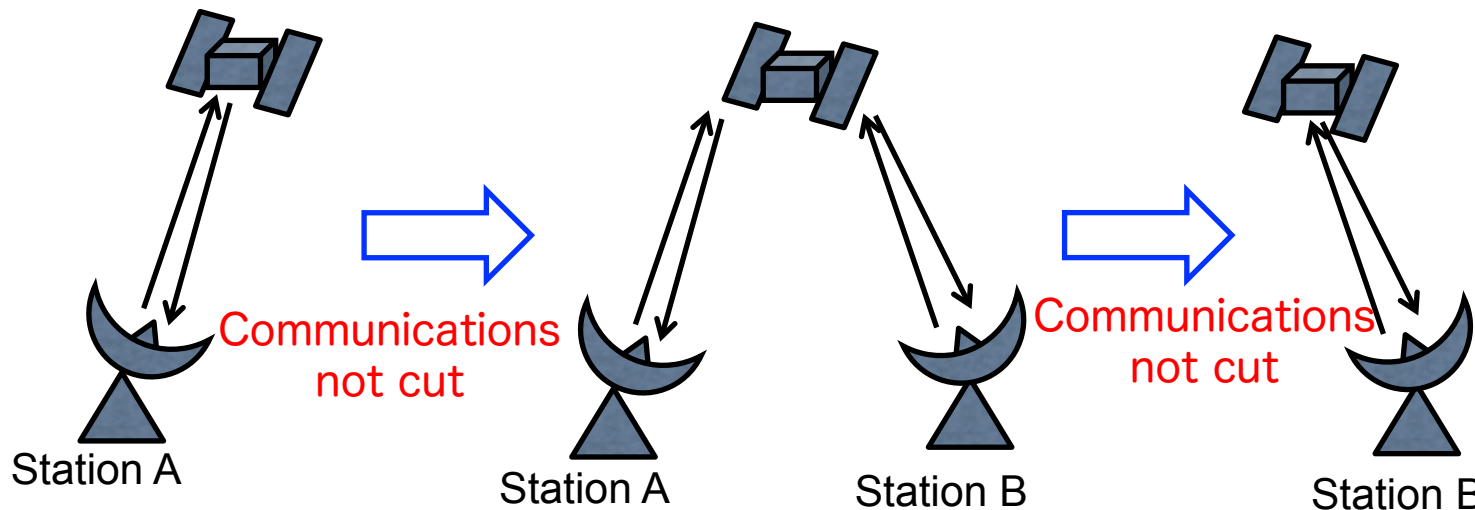

(© JAXA)



Ka-band technology testing: 29 Jun–8 Jul 2016

- 29 Jun–3 Jul 2016: Ka-band communications testing at DSN Stn (Goldstone)
← success from approx. 50 million km!
- 1–2 Jul 2016: Ka-band DDOR testing between NASA–ESA stations (NASA DSN: Goldstone, ESA: Malargüe)
← World-first Ka-band DDOR between 3 organizations!
- 5–8 Jul 2016: Ka-band communications testing at ESA station

X-band (8 GHz): Normal operations

Ka-band (32 GHz): Can transmit approx. 4 times more data than X-band. Used to send asteroid observation data to Earth.

Ka-band is rarely used in deep-space exploration

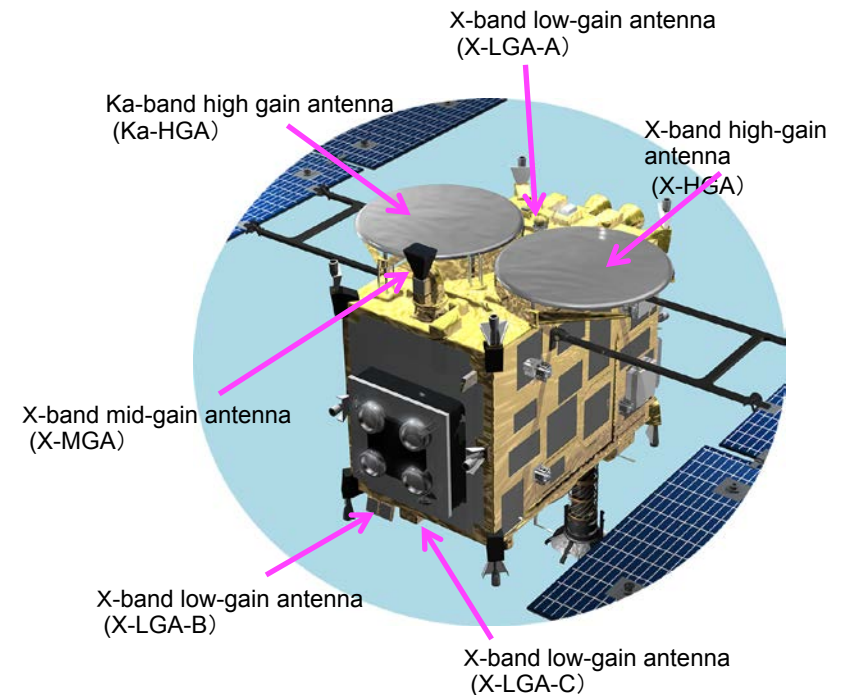



DDOR



DDOR: Delta Differential One-way Ranging

At least two ground stations simultaneously receive radio waves from the spacecraft. In addition, we receive radio waves emitted from a visible celestial body (a quasar) that is as visually close as possible to the spacecraft. By comparing data received at two or more ground stations, the probe trajectory can be determined with high accuracy. (Radio waves from the probe and those from the quasar are received alternately.) This is the same principle as VLBI.

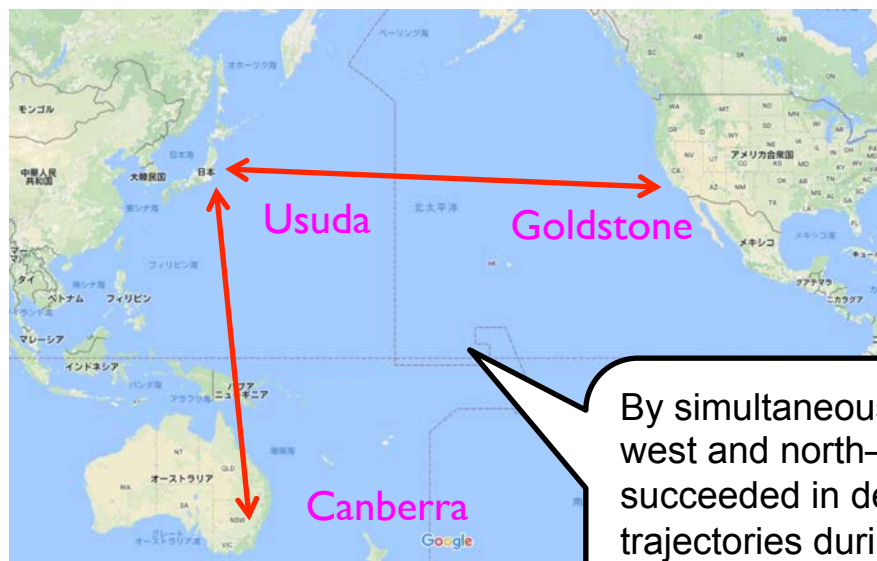
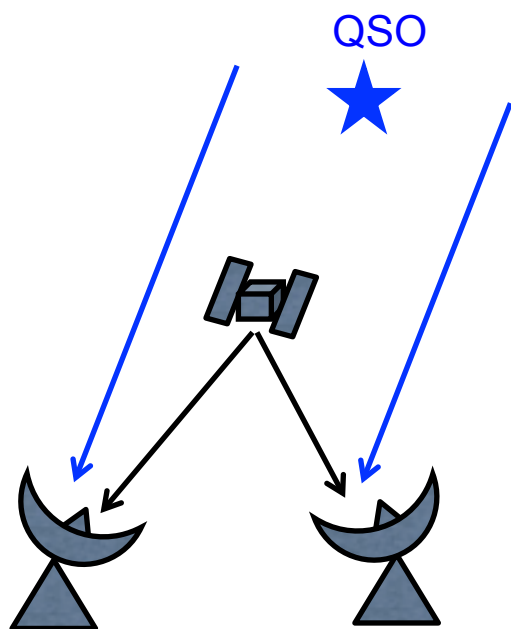

By simultaneously acquiring data along east–west and north–south baselines, we succeeded in determining high-precision trajectories during ion engine operations (micro-thrust accelerations)! **A world's first!**

*Blue arrows are signals from a quasar



Imaging at L₅ (18 Apr 2017)



Observation

- Date: 18 Apr 2017 (Japan time)
- Three sets of four continuous images at 30 min intervals from the Optical Navigation Camera (ONC-T) telescope
- Exposure time: 178 sec (longest exposure)

Results

- No moving objects were seen in any sets

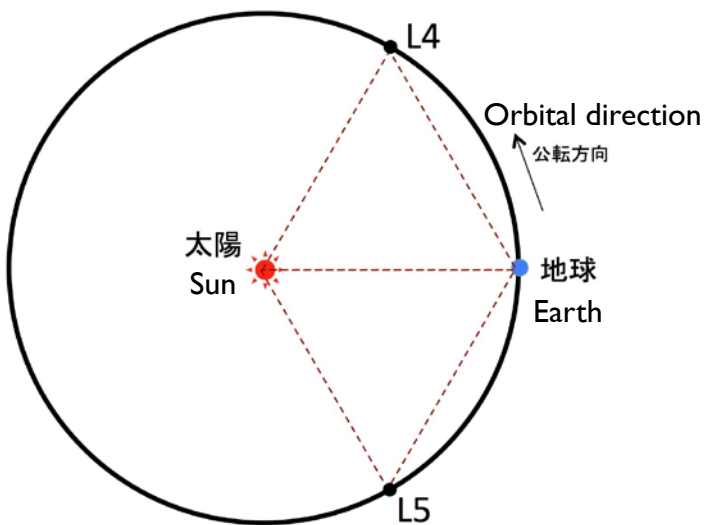

Sun-Earth system Lagrange points L₄, L₅

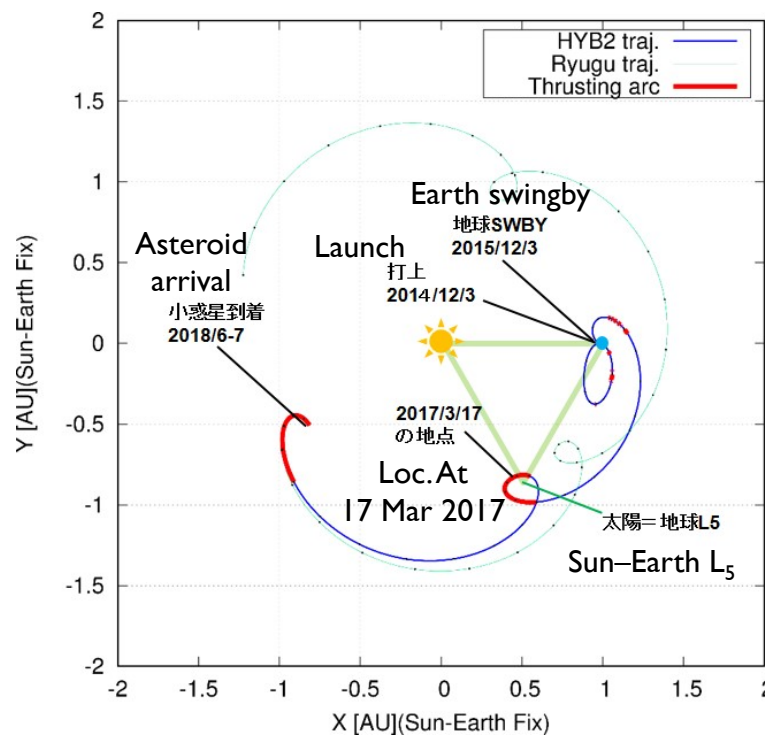

(© JAXA)



Jupiter observation (16–17 May 2017)



- Date: 16 May 2017 17:30 (universal time)
17 May 2017 02:30 (Japan time)
- View angle: 0.79×0.79 deg
- Exposure time: 0.1312 s
- Wavelength: v-band (550 nm)
- Distance to Jupiter (16 May 2017 17:30 UT):
 4.48565 au (6.71044×10^8 km)
- Magnitude as seen from spacecraft: -2.44
- Imaging objective:
Various devices aboard Hayabusa2 perform observations in preparation for arrival at the asteroid about one year later. The figure shows a calibration observation for the visible spectroscopic camera, targeting Jupiter as the brightest planet.

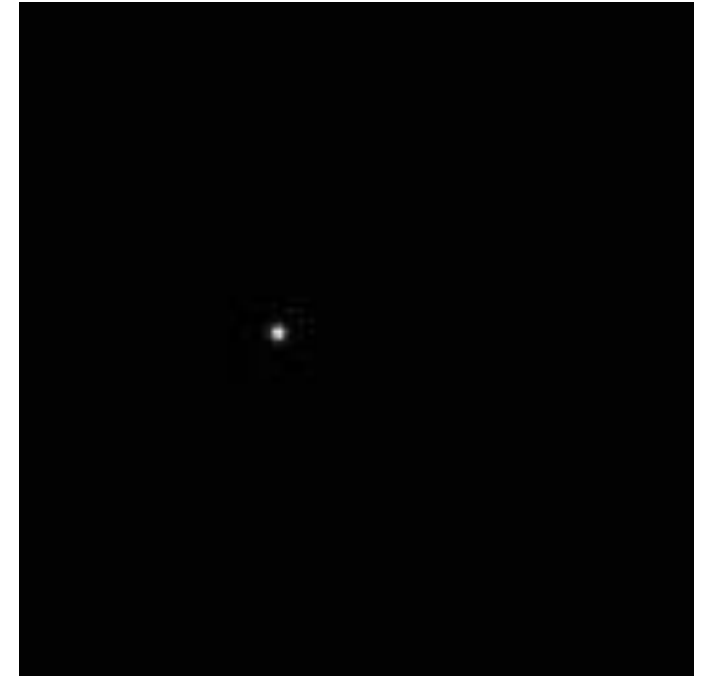

Jupiter as imaged by ONC-T



TI reset (5 Sep 2017)



- Time (TI) reset of the spacecraft clock
- Clock is reset through operations on 5 Sep 2017
- No need for further resets until return to Earth

■ Description

- Spacecraft-internal time counter: 32 bits
- Time count: 1 count = approx. 31 ms (1 ms = 1/1000 s)
- 32 bits allows counting to 4,294,967,296 (approx. 4 yr 3 mo)
- Counter reverts to zero after reaching max value (like a car odometer)
- This is performed to avoid a counter value of zero during stay at Ryugu

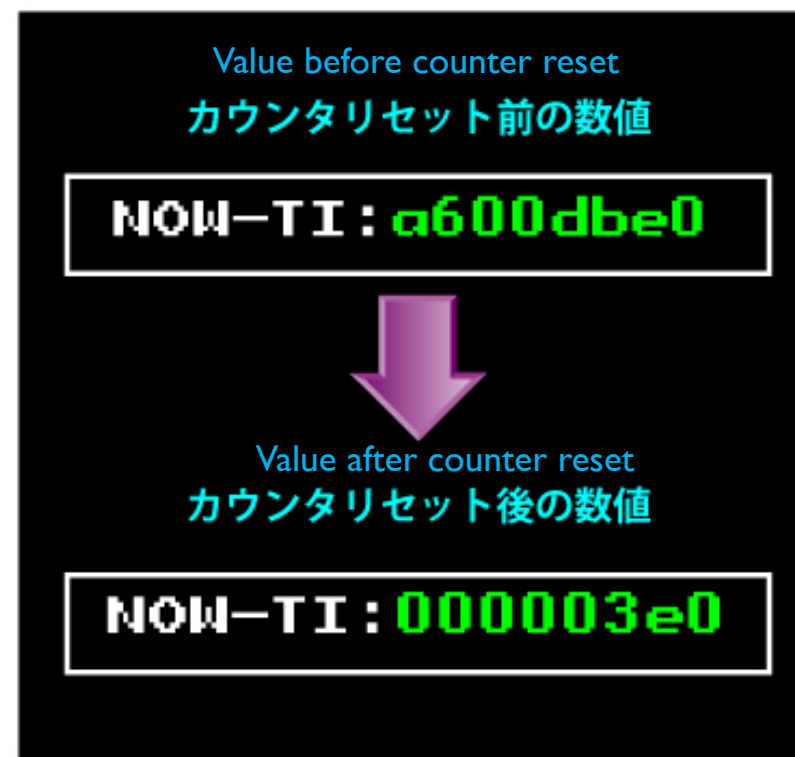



First observation of Ryugu (26 Feb 2018)



- Successful imaging of Ryugu by the onboard ONC-T camera on 26 Feb 2018
- Observation conditions were good on this day; Ryugu was in the ONC-T FoV without making large attitude corrections.
- Distance from spacecraft to Ryugu was approx. 1.3 million km

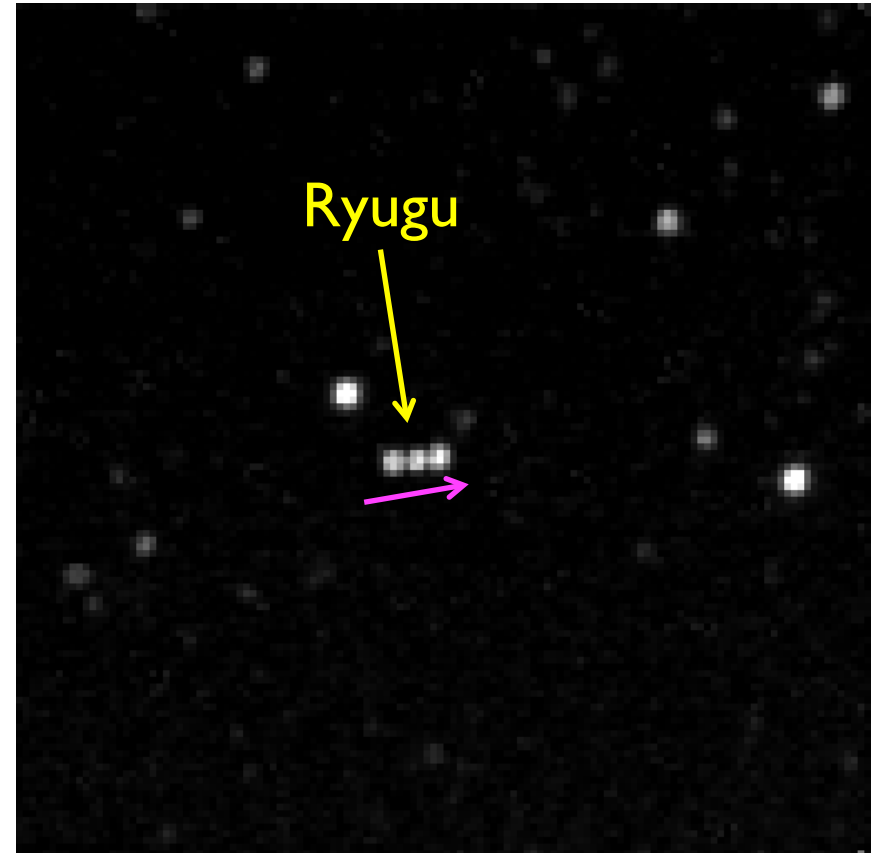

Three images are overlaid. Ryugu is moving in the direction of the pink arrow. View angle in the image is 0.8 deg)

(ONC team: JAXA, Univ. Tokyo, Kochi Univ., Rikkyo Univ., Nagoya Univ., Chiba Inst. of Tech., Meiji Univ., Aizu Univ., AIST)



4. Trajectories



Trajectories overview

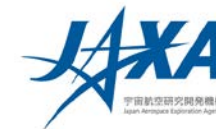

After launch, the spacecraft enters a trajectory close to Earth orbit, and returns to Earth for a swing-by exactly 1 year later. After the swing-by, it enters a trajectory close to orbit of asteroid Ryugu, arriving there after about two orbits. It will remain at Ryugu over a little more than one revolution around the sun. After that, it will leave Ryugu, revolve around the sun for a little more than one orbit, then return to Earth.

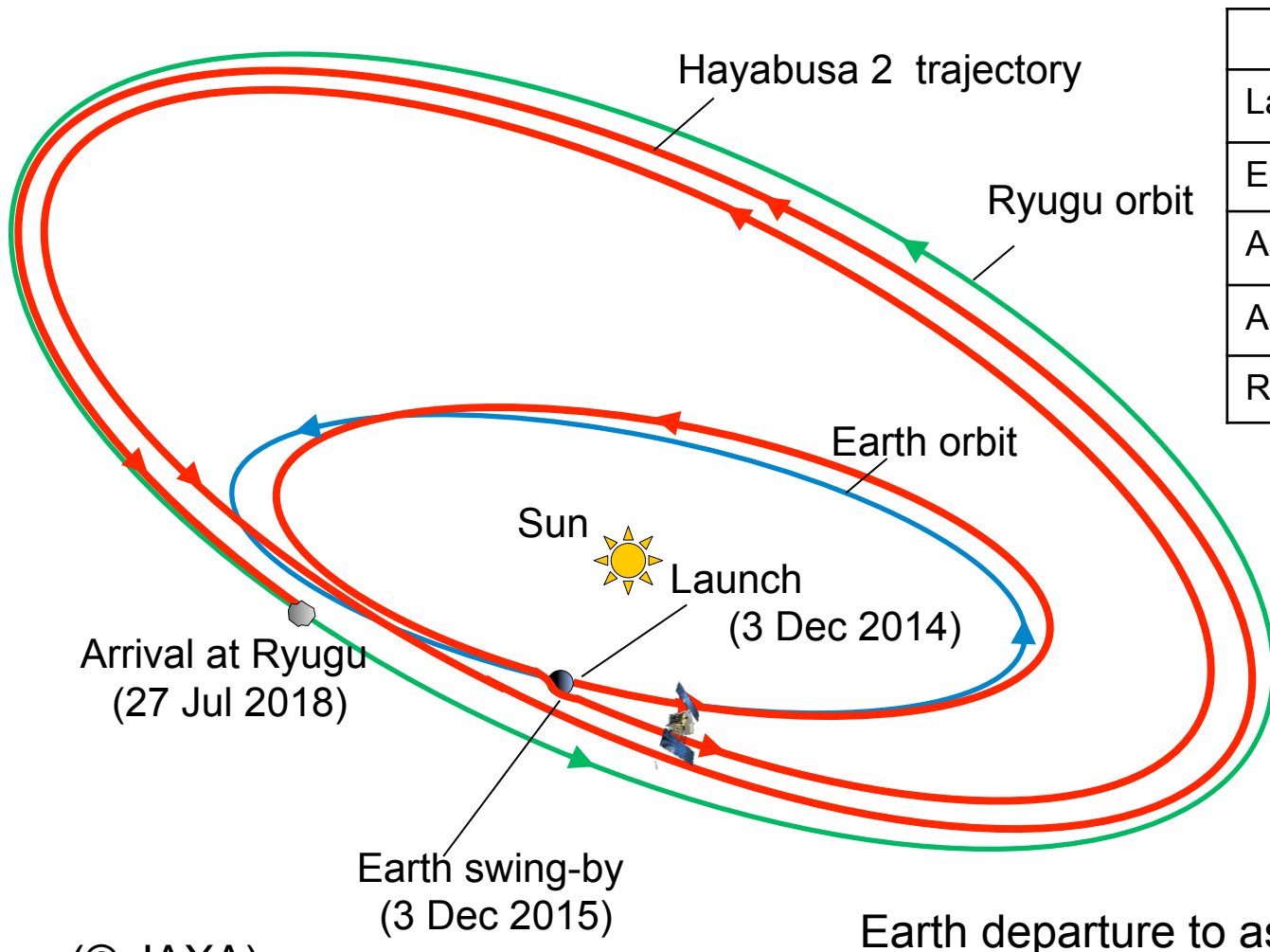

Event	Date
Launch	3 Dec 2014
Earth swing-by	3 Dec 2015
Asteroid arrival	27 Jul 2018
Asteroid departure	Nov - Dec 2019
Return to Earth	Nov - Dec 2020



Trajectories: Launch to Earth swing-by

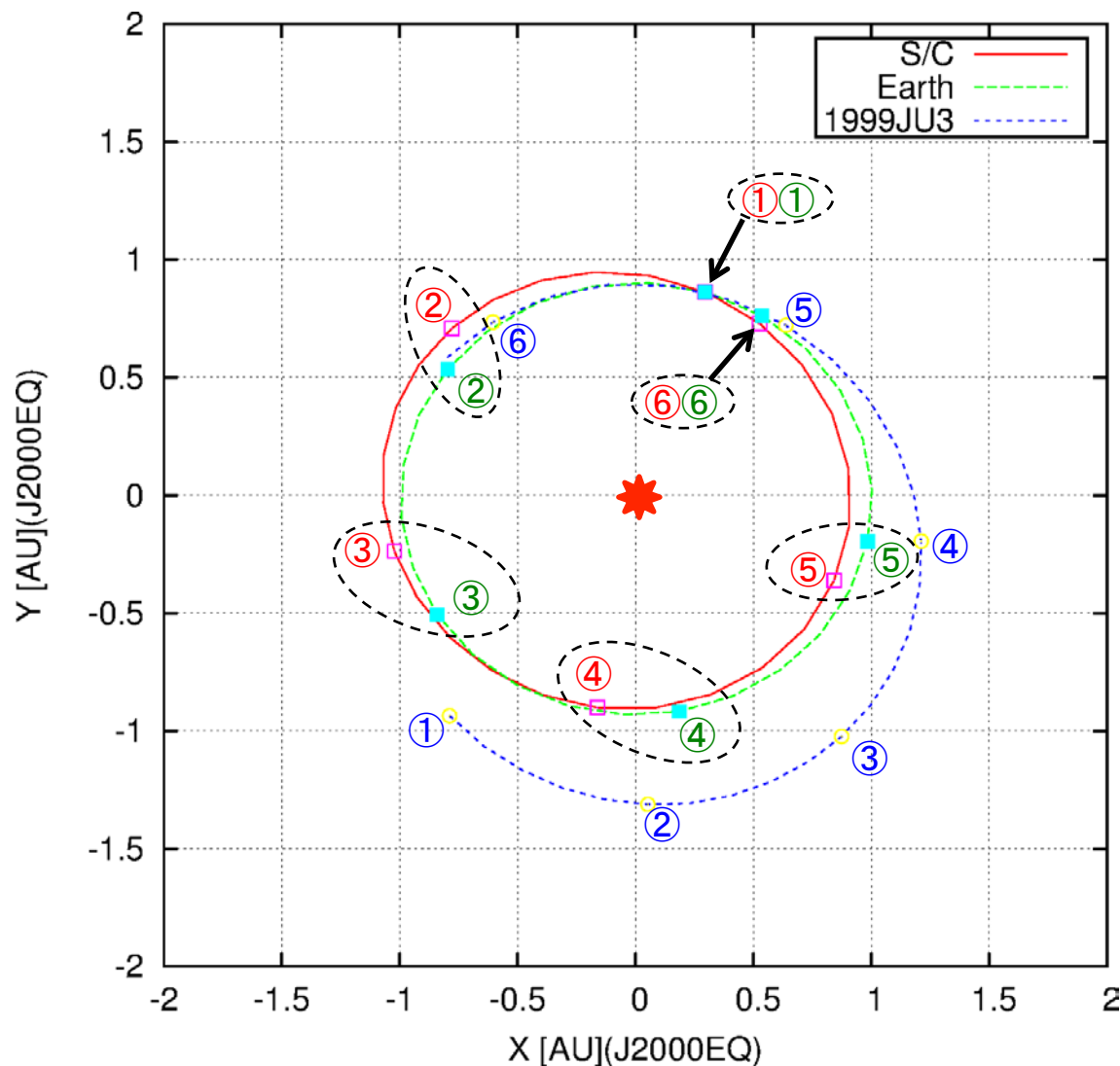

- ①①①: Dec 2014
- ②②②: Feb 2015
- ③③③: Apr 2015
- ④④④: Jul 2015
- ⑤⑤⑤: Sep 2015
- ⑥⑥⑥: Nov 2015

Red: Hayabusa2
 Blue: Ryugu
 Green: Earth

(© JAXA)

Launch near ①, return and Earth swing-by near ⑥. There is little distance between Earth and Hayabusa2.



Trajectories: Earth swing-by to first orbit

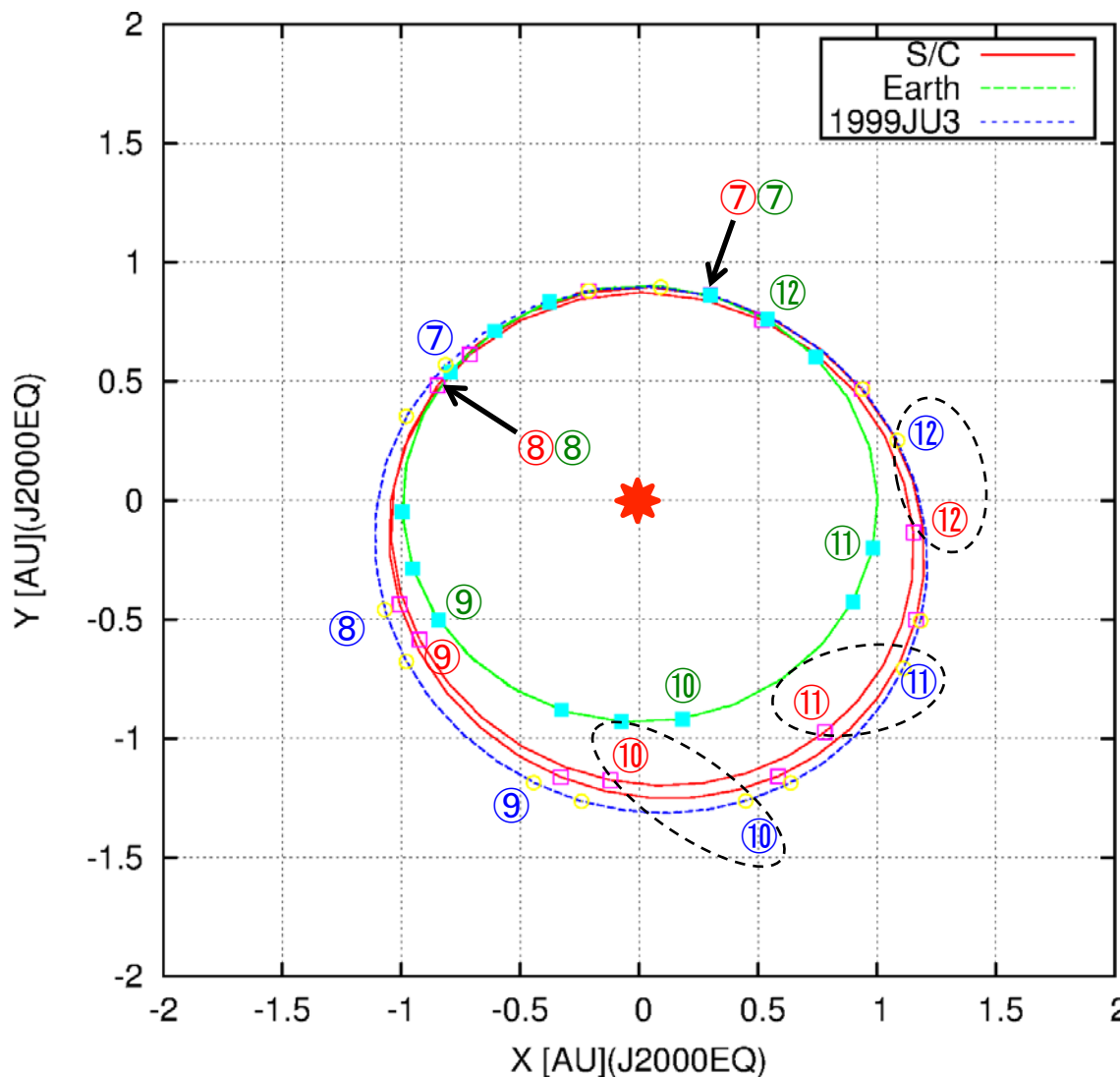

After Earth swing-by near ⑦, Hayabusa2 leaves Earth and gradually approaches Ryugu (at ⑫).



Trajectories: First to second orbit (asteroid arrival)

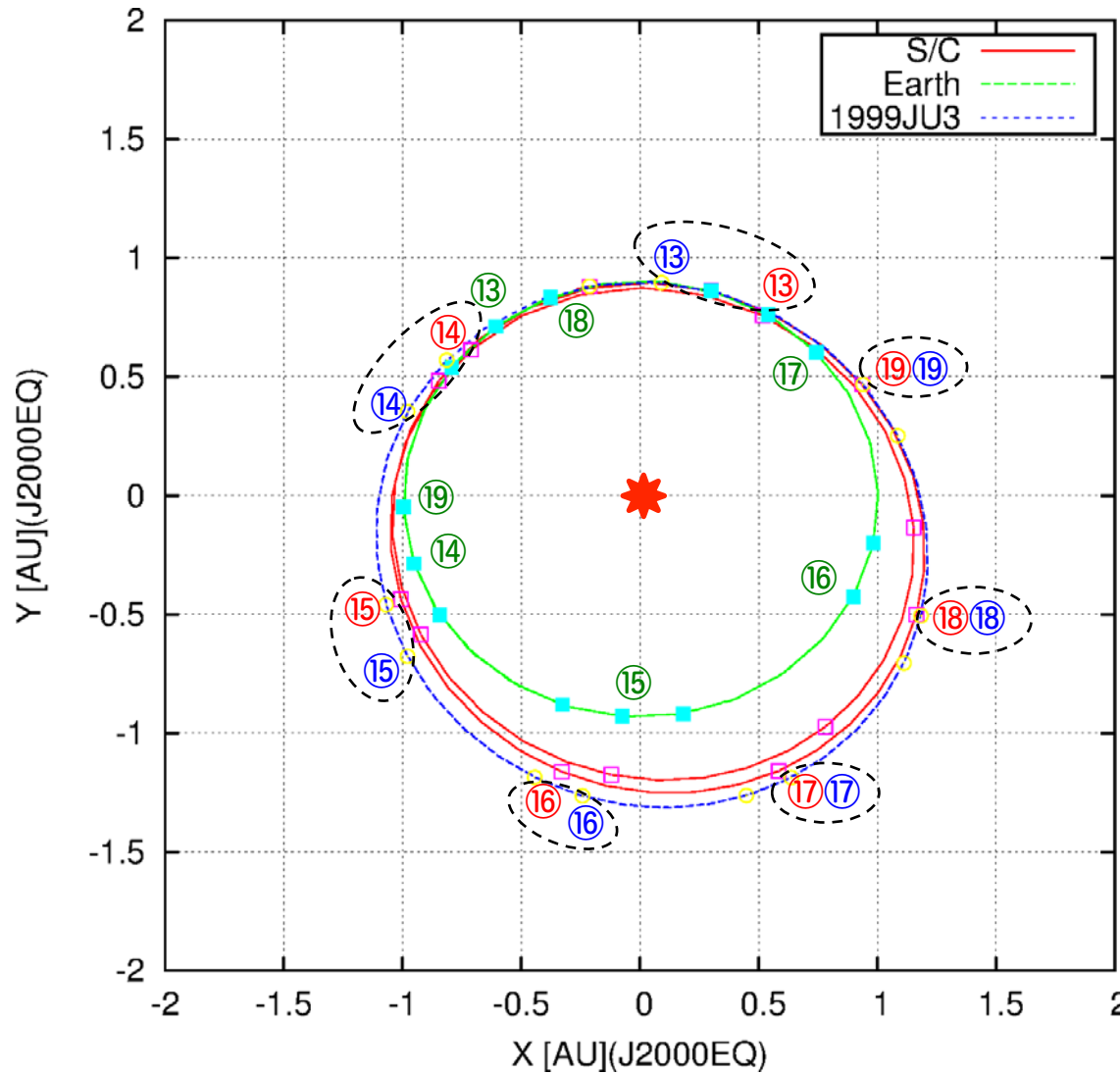

⑬⑬⑬: Jan 2017

⑭⑭⑭: Apr 2017

⑮⑮⑮: Jun 2017

⑯⑯⑯: Aug 2017

⑰⑰⑰: Nov 2017

⑱⑱⑱: Jan 2018

⑲⑲⑲: Mar 2018

Red: Hayabusa2

Blue: Ryugu

Green: Earth

(© JAXA)

While making one more orbit from ⑬ to ⑲, Hayabusa2 makes one more orbit while approaching Ryugu.



Trajectories: Stay at asteroid

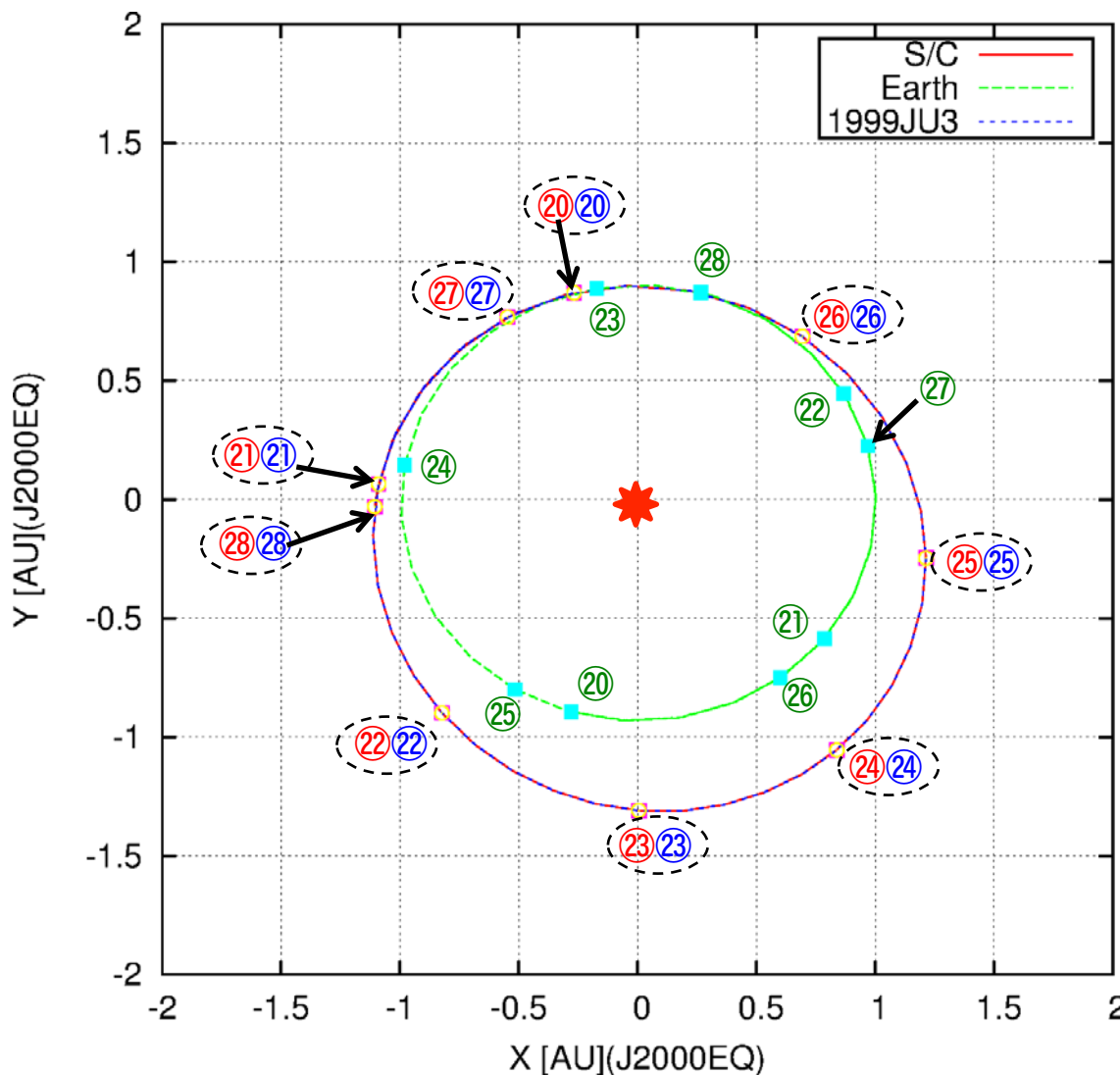

- ②①②①②①: Jun 2018
- ②②②②②②: Aug 2018
- ②③②③②③: Oct 2018
- ②④②④②④: Jan 2019
- ②⑤②⑤②⑤: Mar 2019
- ②⑥②⑥②⑥: May 2019
- ②⑦②⑦②⑦: Jul 2019
- ②⑧②⑧②⑧: Oct 2019
- ②⑨②⑨②⑨: Dec 2019

Red: Hayabusa2

Blue: Ryugu

Green: Earth

(© JAXA)

Hayabusa2 arrives at Ryugu near ②①, and travels with the asteroid for over one solar orbit to ②⑧.



Trajectories: Asteroid to Earth

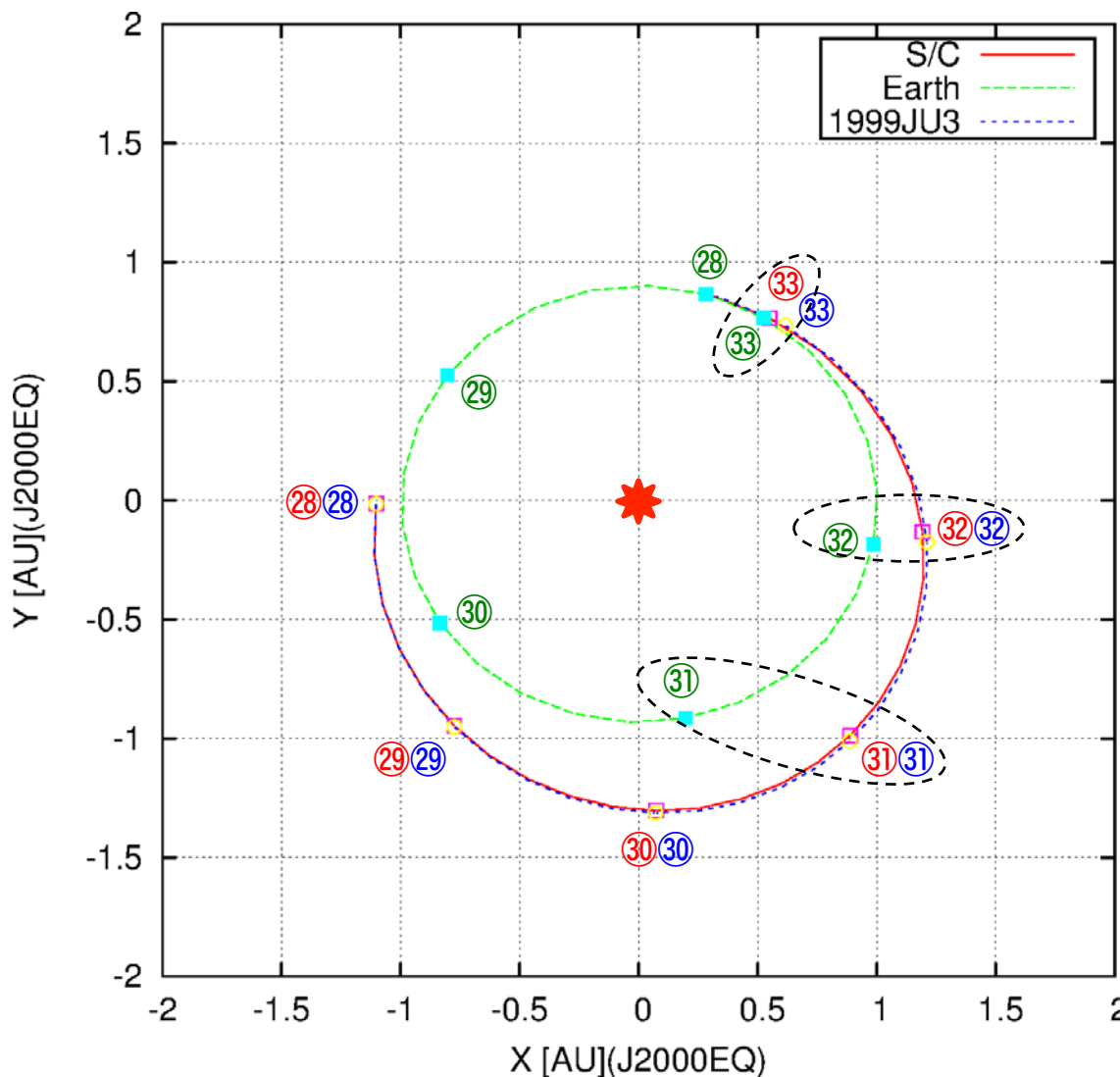

- ②⑧ ②⑧ ②⑧: Dec 2019
- ②⑨ ②⑨ ②⑨: Feb 2020
- ③① ③① ③①: Jul 2020
- ③② ③② ③②: Sep 2020
- ③③ ③③ ③③: Nov 2020

Red: Hayabusa2

Blue: Ryugu

Green: Earth

(© JAXA)

Hayabusa2 departs Ryugu at around ②⑧, then heads directly to Earth to return the capsule near ③③.



Trajectories in rotational coordinates



Earth departure 3 Dec 2014
 Earth swingby 3 Dec 2015
 Ryugu arrival 27 Jun 2018
 Ryugu departure Nov–Dec 2019
 Earth re-entry Nov–Dec 2020

$C3 = 21 \text{ km}^2/\text{s}^2$
 Ion engine total impulse
 = 2 km/sec
 Re-entry speed = 11.6 km/s

Total flight time = 6 yr (4.5 yr cruising time)
 Total powered flight time = 1.5 yr

Total flight distance = 5,240,000,000 km

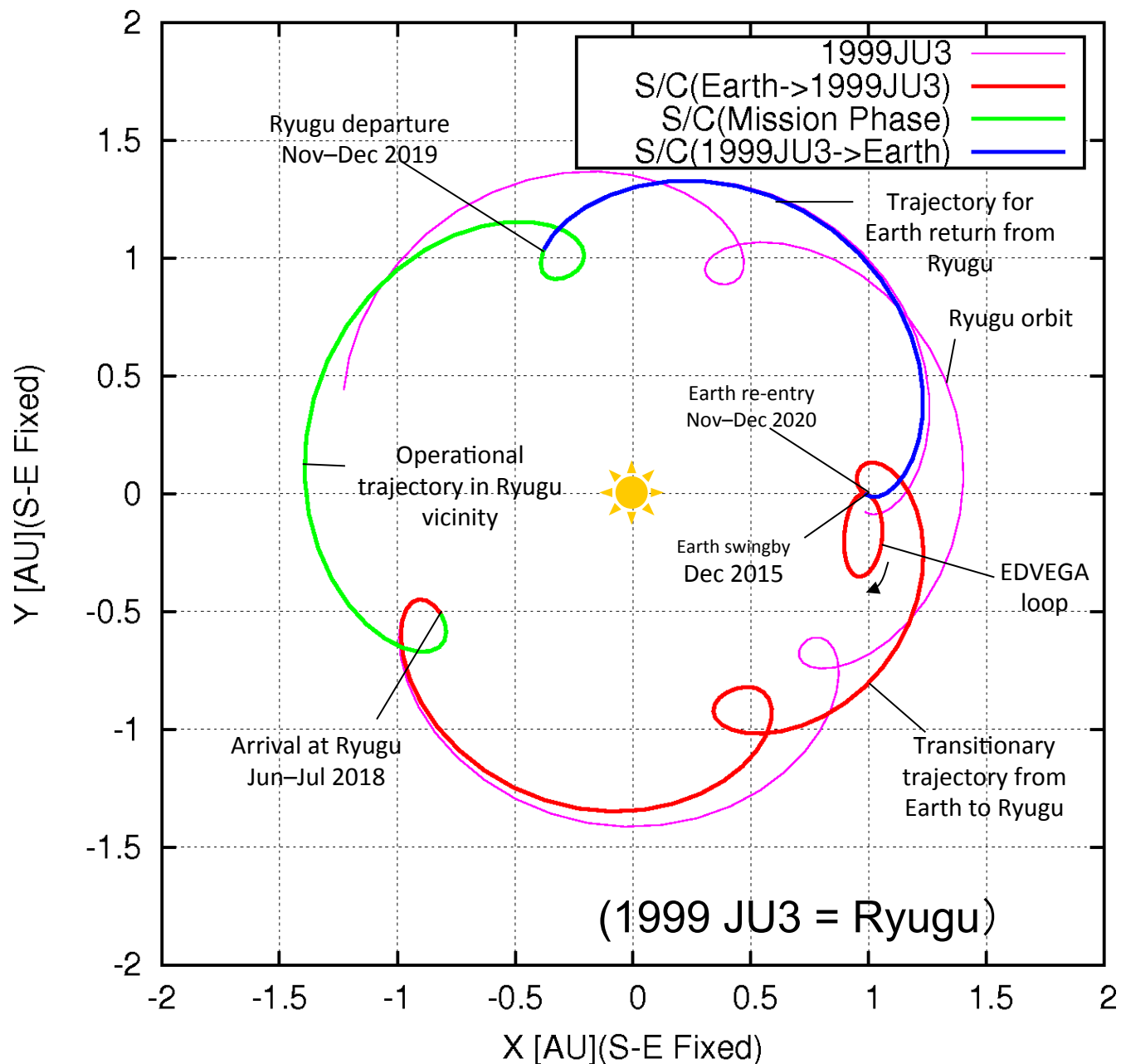

(© JAXA)



Earth swing-by



- Hayabusa2 approached Earth for a swing-by on 3 Dec 2015.
- Earth approach time: 19:08 (Japan time)
- Passed approximately 3,090 km over the Hawaiian islands

Overview of orbits

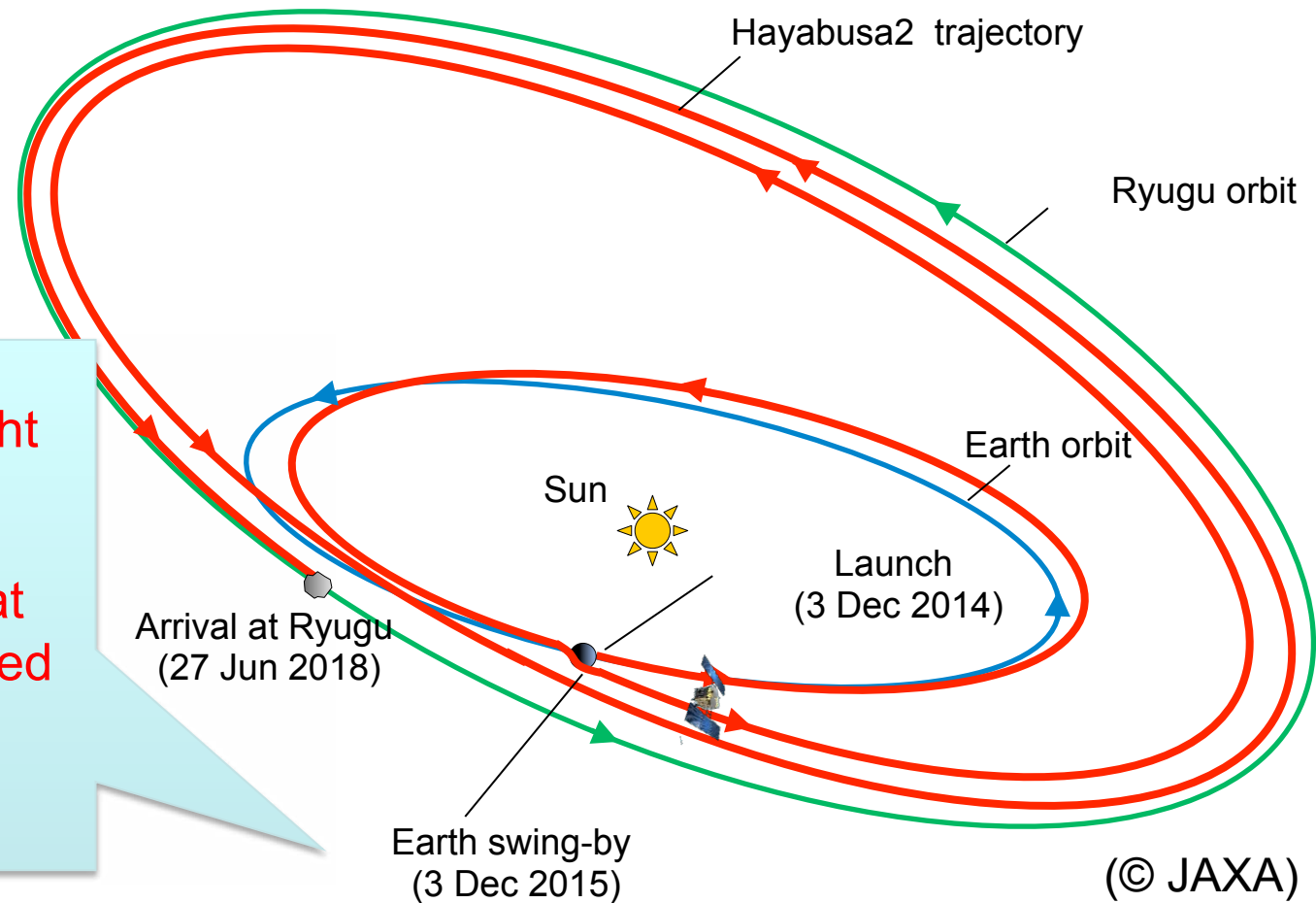

Swing-by increases flight speed by 1.6 km/s.

Solar relational speed at time of swing-by changed from 30.3 km/s to 31.9 km/s.

(© JAXA)



Swing-by trajectory

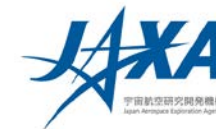

Solar system view from north

Diagrams depicting orbits around the sun. These figures show orbits of Earth and Hayabusa 2 around the sun. The degree of curvature of the Hayabusa 2 orbit at the swing-by point thus appears small.

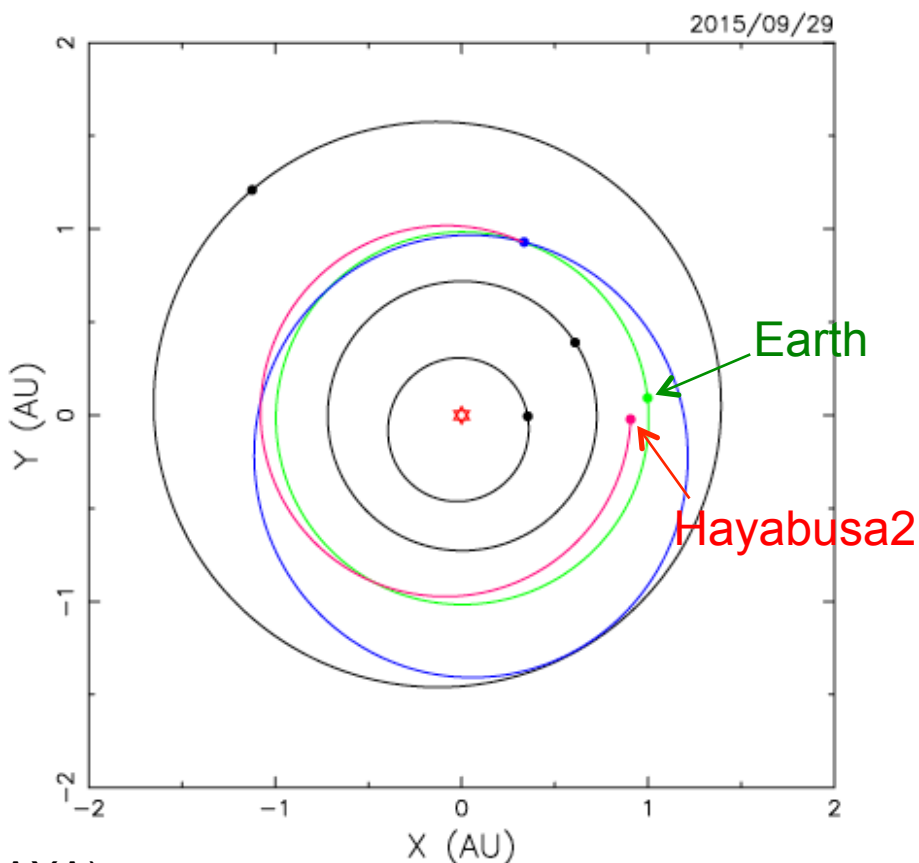

(© JAXA)

Before swing-by (Sep 2015)

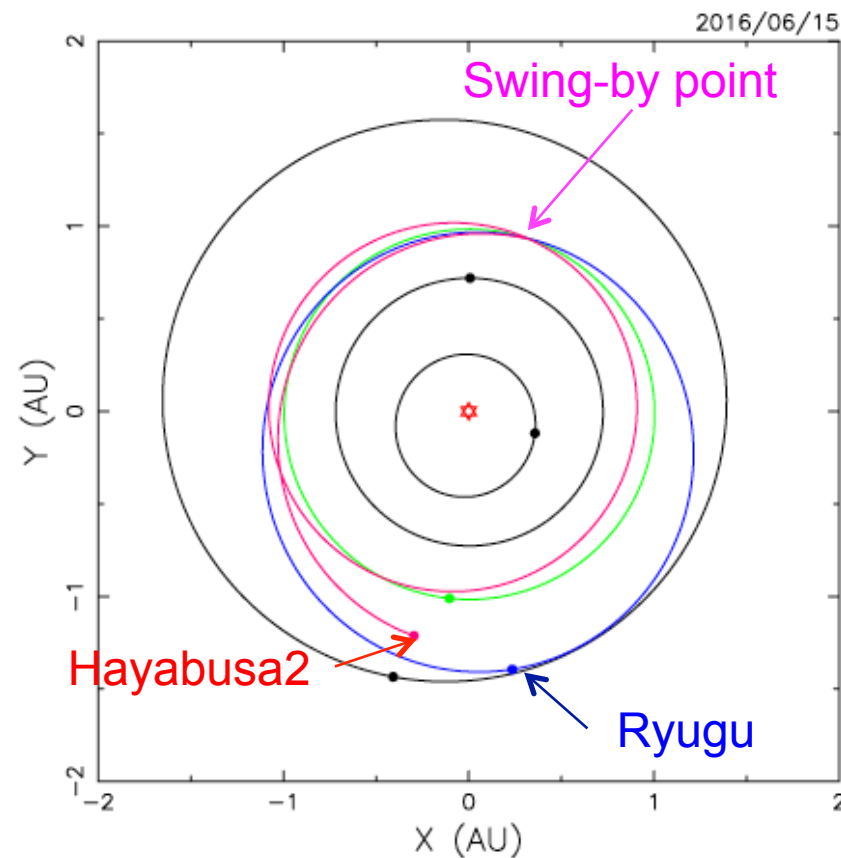

After swing-by (Jun 2016)



Operations before and after swingby

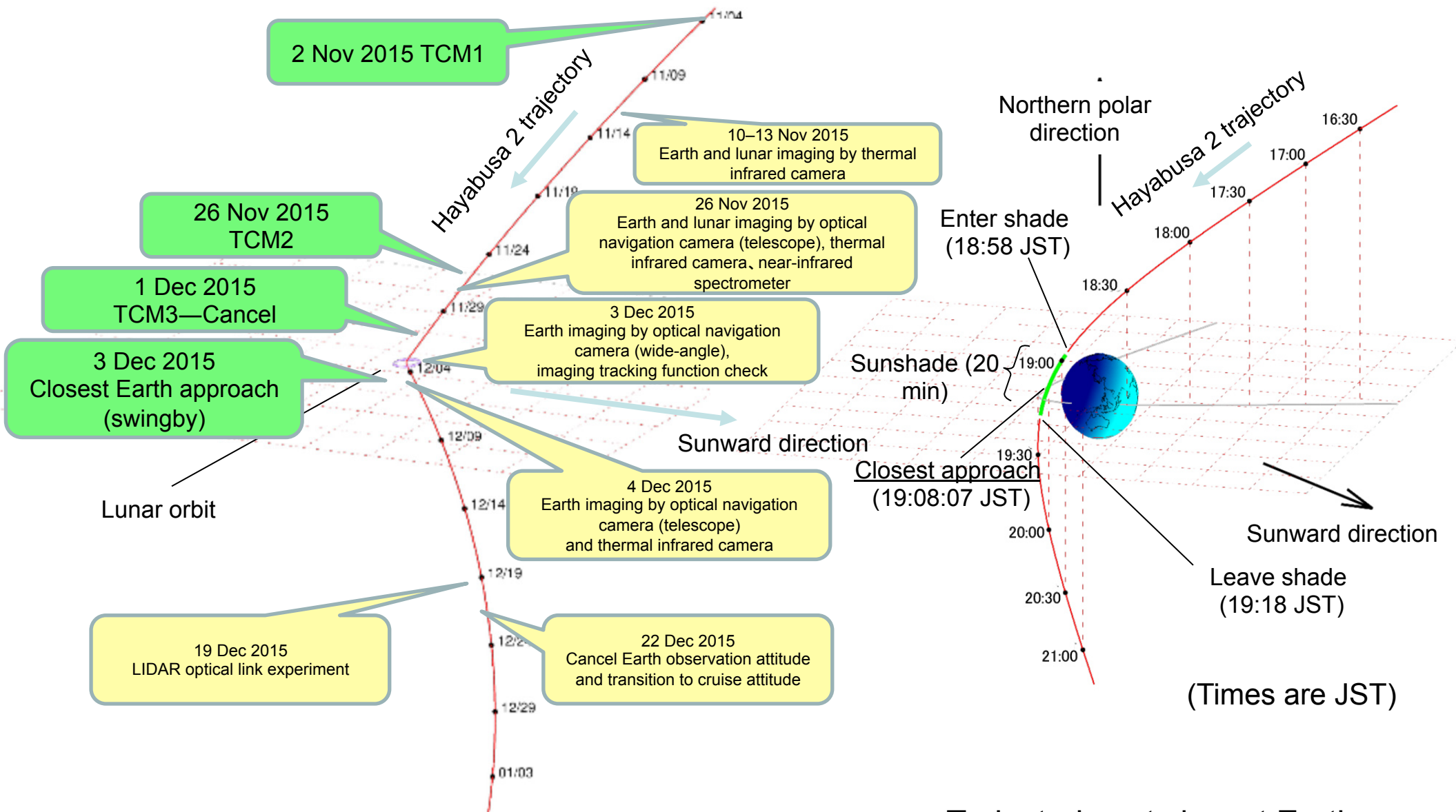

Primary operations before and after Earth swing-by

Trajectories at closest Earth approach



Principle of swing-bys



Earth region escape velocity

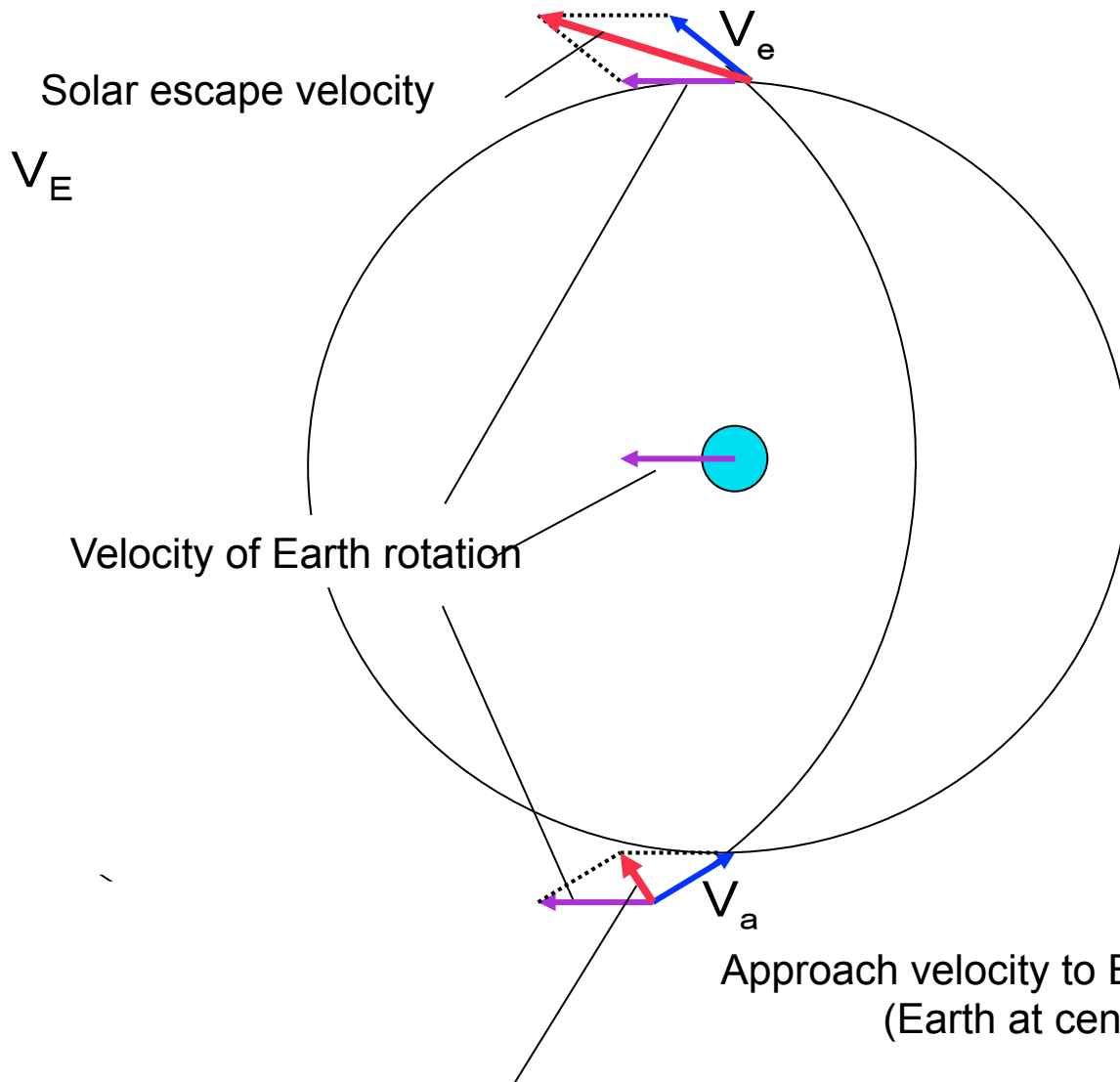

Change in velocity relative to sun

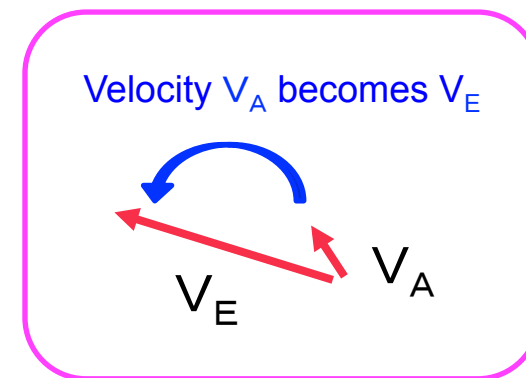

Approach velocity with respect to sun

V_A



Simple description of swing-bys

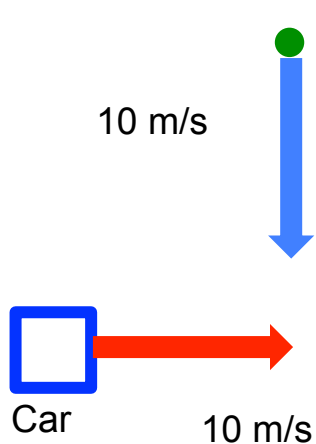

Throw a ball at 10 m/s at a right angle toward a car travelling at 10 m/s.

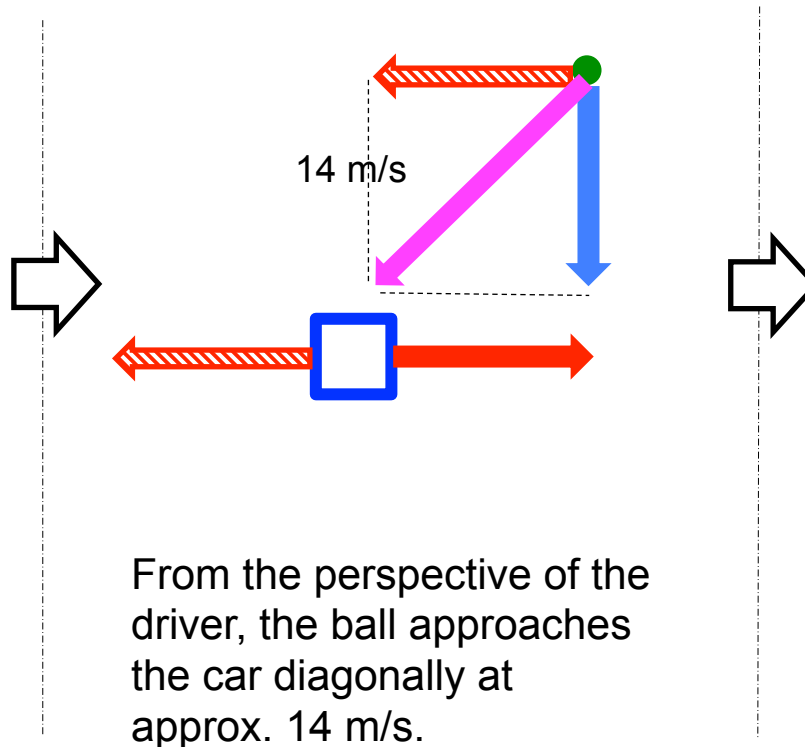

From the perspective of the driver, the ball approaches the car diagonally at approx. 14 m/s.

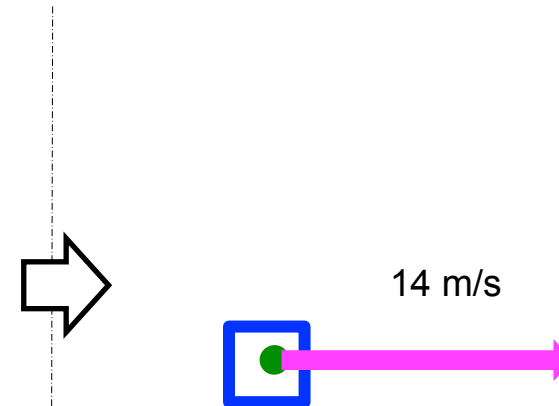

The driver catches the ball, and throws it at 14 m/s in the direction of travel.

The direction of ball travel has changed by 90 deg, and its speed increased from 10 m/s to 24 m/s.

In this metaphor, Hayabusa2 is the ball, and Earth and its gravity are the car and the driver

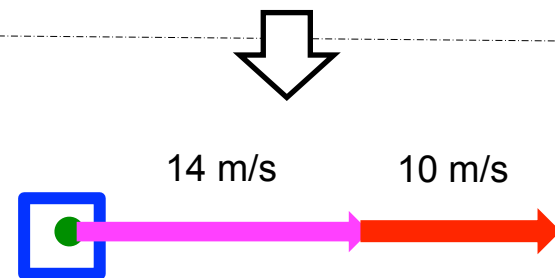

The ball is now travelling at 24 m/s with respect to the ground



5. Near-asteroid operations



Sampling operation sequence



- ① Separate from home position, start GCP-NAV (combined ground/onboard navigation)
- ② Enter automatic mode
- ③ Deploy target markers
- ④ Attitude adjustment with regard to asteroid surface
- ⑤ Touchdown
- ⑥ Shelter ΔV



Automatic/autonomous technologies
||
GSP, GCP-NAV

(© JAXA)

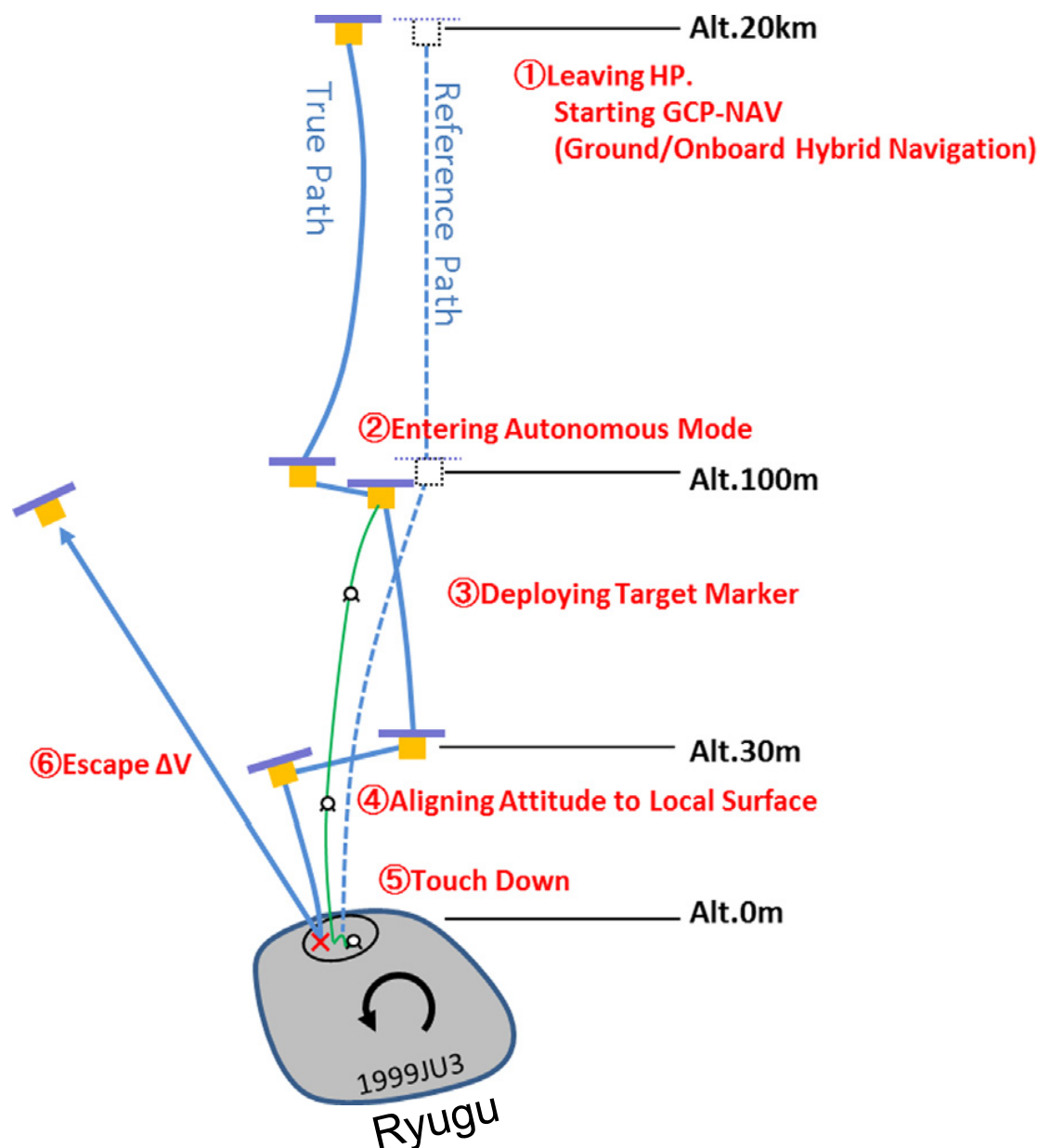



Automatic/autonomous technologies: GSP, GCP-NAV

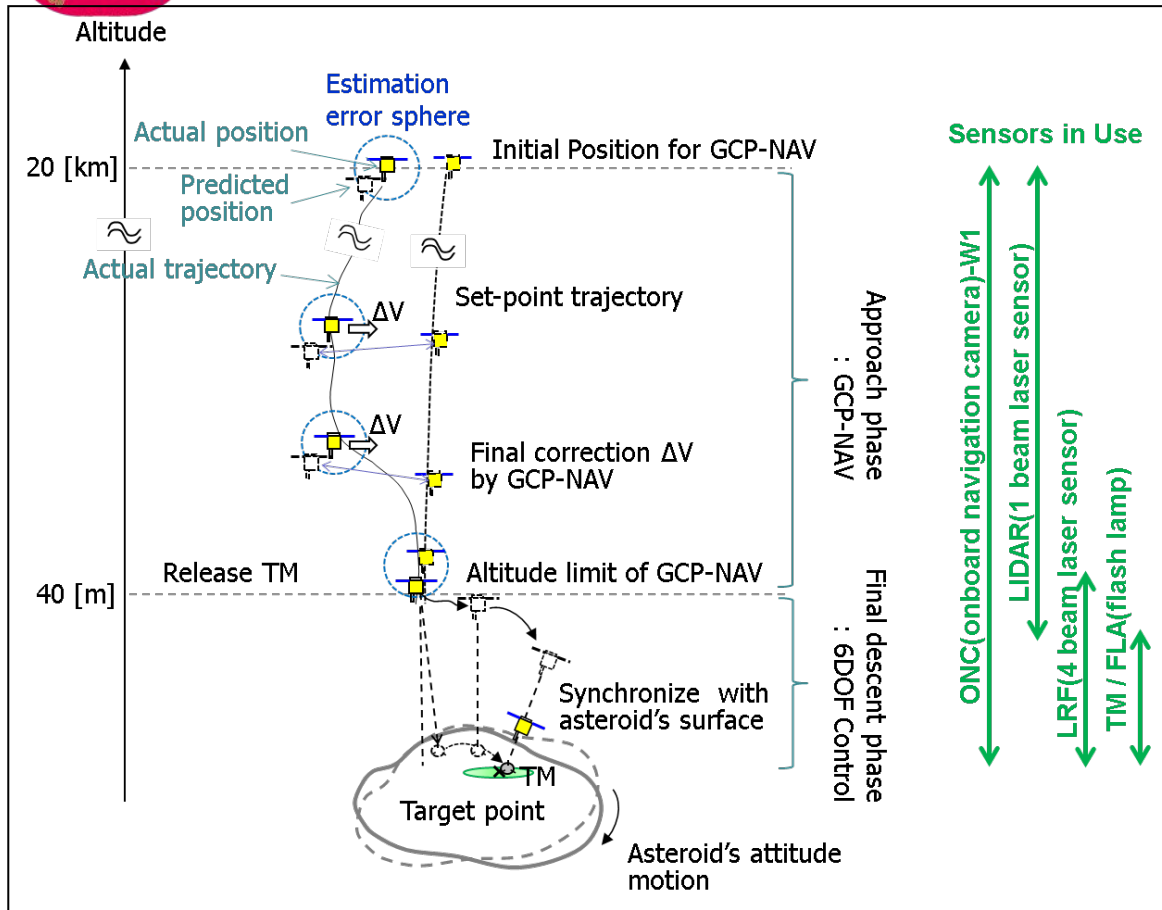
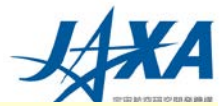

- Ground Control Point Navigation (GCP-NAV)
- ✓ Used for remote operations during approach from 20 km to several hundred meters.
- ✓ Satellite images transmitted to ground. By matching feature points and contours of the asteroid with computer generated template images, we can detect position and attitude information of the spacecraft and the asteroid.
- ✓ Based on this, calculate levels of engine thrust on the ground and issue commands to the spacecraft.
- ✓ Human beings are good at recognizing complex images and instantaneous judgments of the overall situation. Ground instructions are thus advantageous despite the communication time lag.

• Guidance Sequence Program (GSP)

- ✓ From sensor information, autonomous behavior patterns performed by the spacecraft can be efficiently rewritten and delivered from the ground.
- ✓ We first obtain asteroid information that can only be derived through proximal observations, such as its surface conditions and reflectivity. Operators on the ground analyze this information to determine risk assessments and how to handle emergency situations. Before starting autonomous operations, ground commands are sent to rewrite tables in the spacecraft.
- ✓ Efficient rewriting and instruction mechanisms are important for accommodating spacecraft restrictions on communications capacity and computer memory.

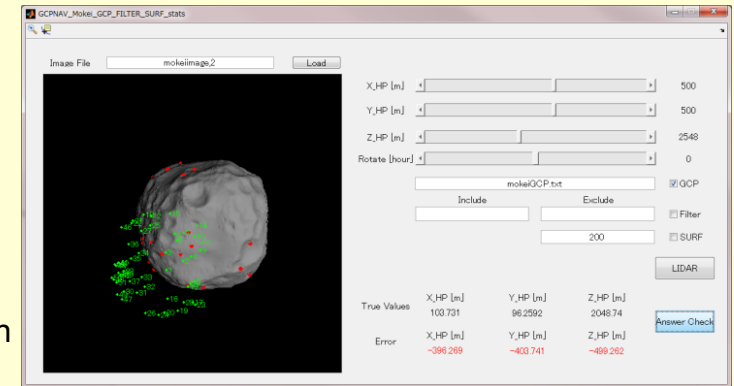

Example of GCP-NAV operation screen

(© JAXA)



Impactor operations sequence

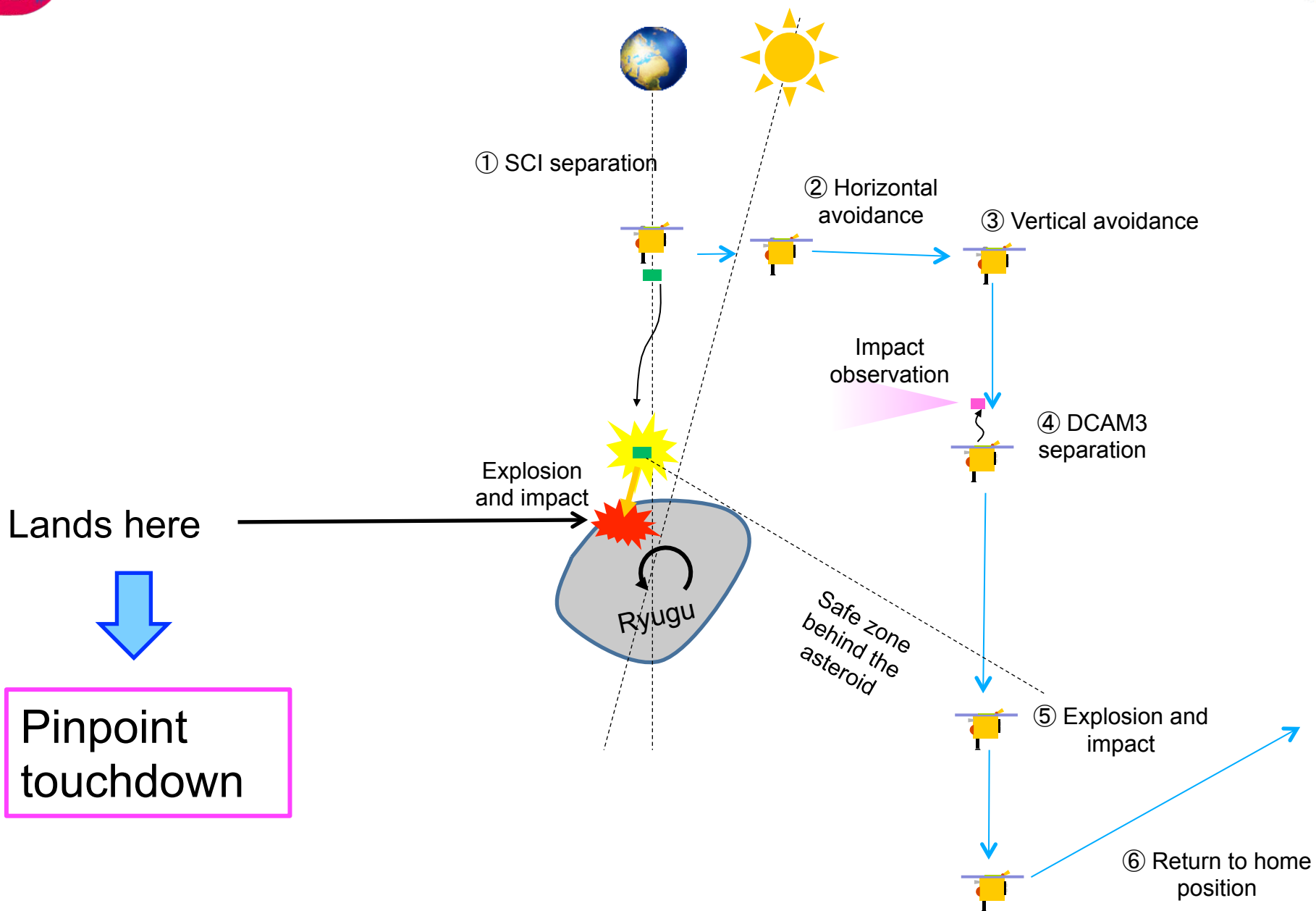

(© JAXA)



Impactor: Debris and ejecta avoidance

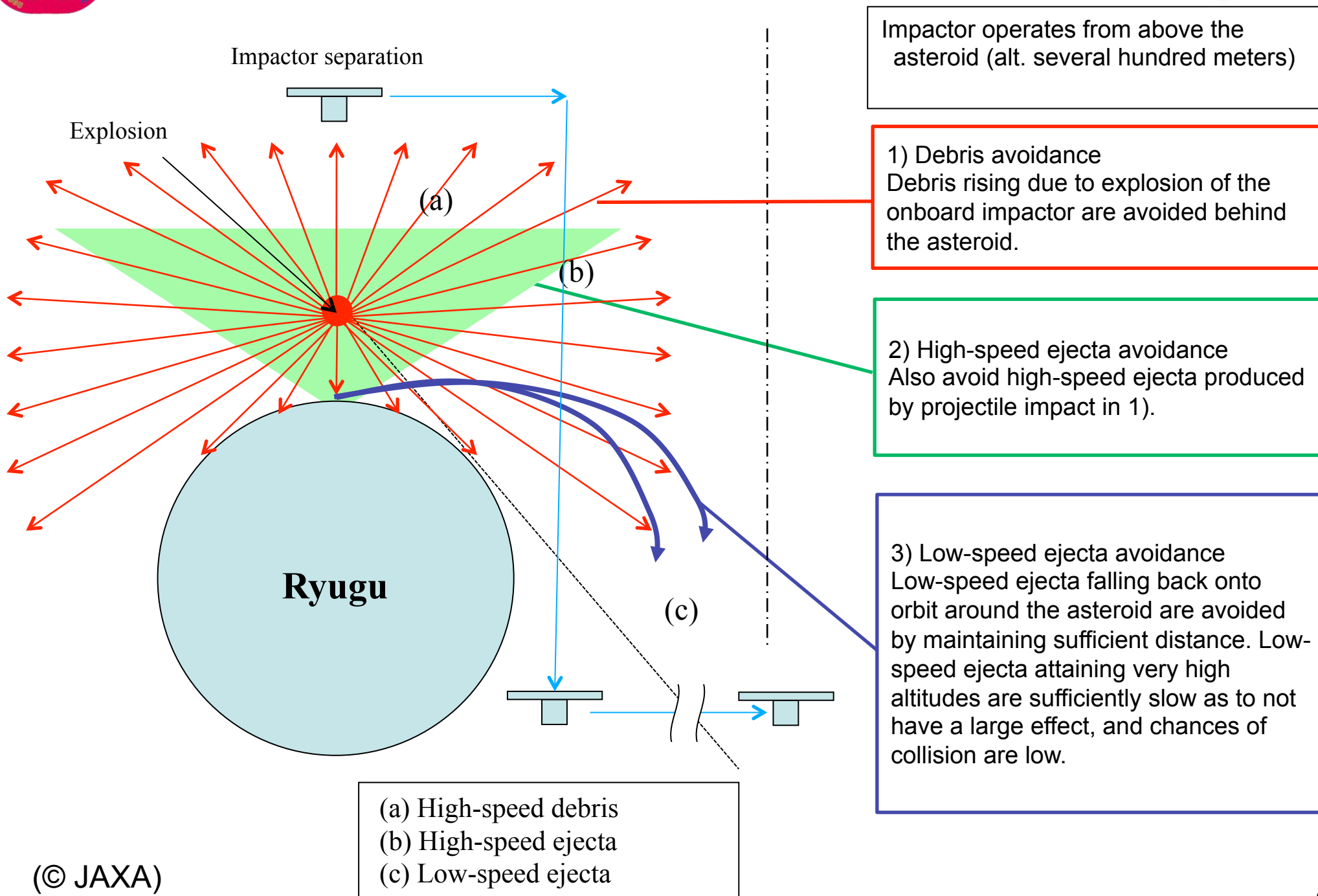
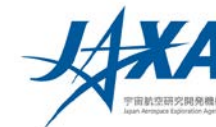



Pinpoint touchdown

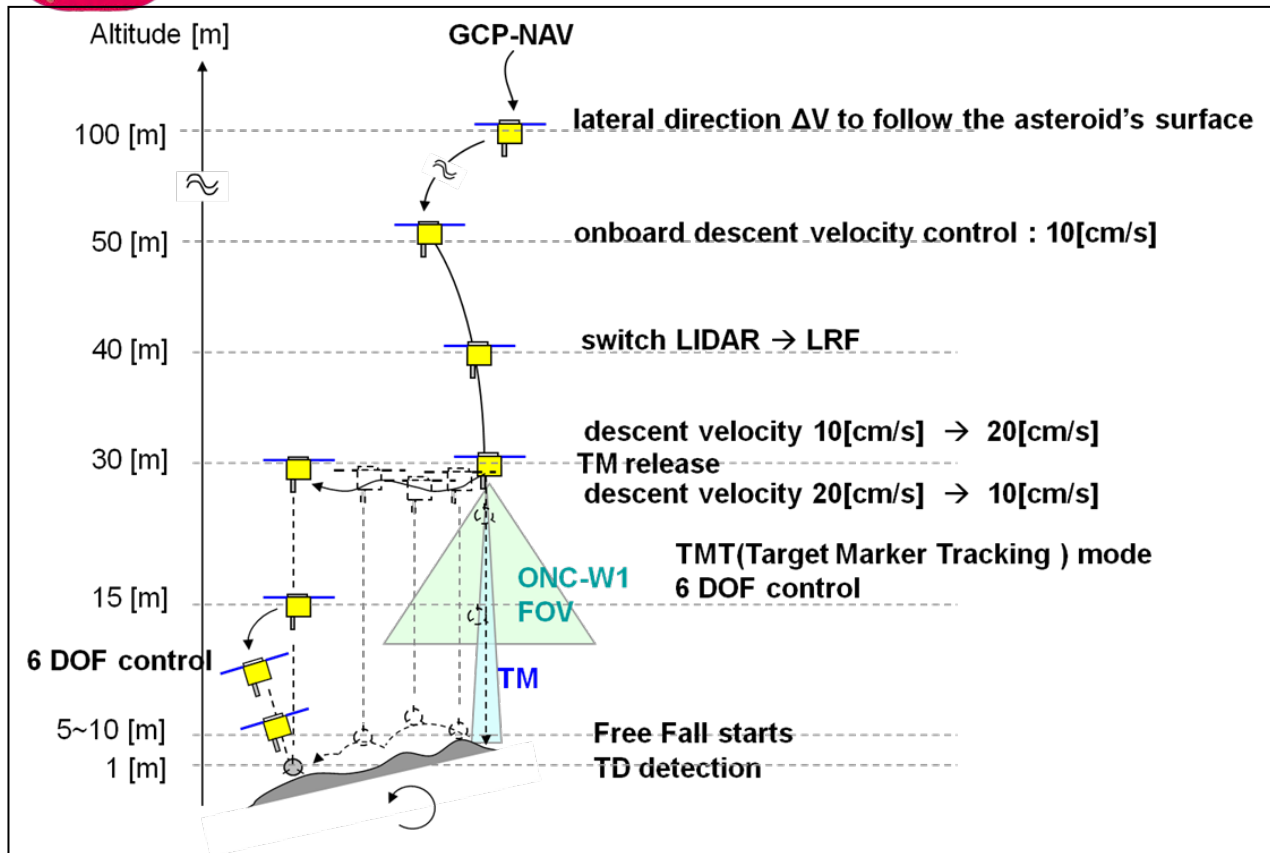
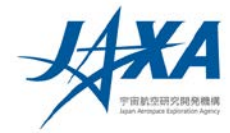

- Target Markers (TM)
- ✓ TM separate at an altitude of several tens of meters, and flash lamps intermittently illuminate TM while cameras image them.
- ✓ By comparing differences in images when flash lamps are lit and when they are not, we can accurately extract TM without effects from surface patterns or sunlight.
- ✓ Facing toward identified TM, descend to the asteroid while using laser altimeter information to determine attitude and distance to the surface.
- ✓ 6-degree-of-freedom (position + attitude) gas jet injection control with high target tracking while minimizing fuel consumption is also a key technology.

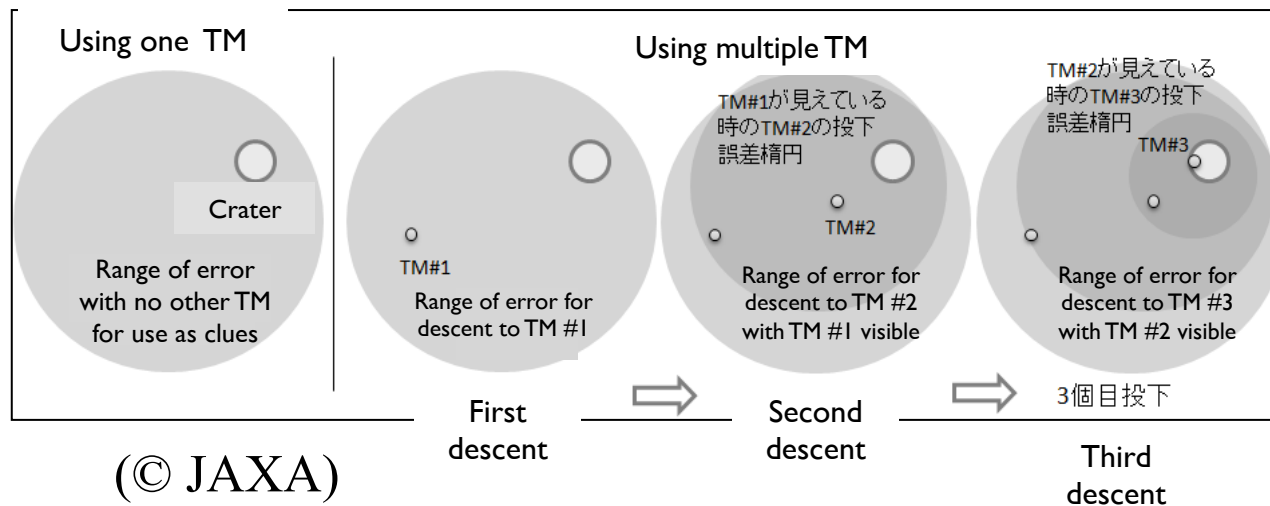

- Use of multiple TM
- ✓ We will touch down near the artificial crater, and attempt to retrieve samples from exposed areas.
- ✓ We expect the artificial crater to have a diameter of around several meters. By approaching the destination point based on clues from multiple sequential TM, we can perform the touchdown with higher precision (a pinpoint touchdown).



Spacecraft trajectory calculation near the asteroid



Considering the forces described here, calculate the trajectory of the spacecraft.

Known

*Because planetary orbits around the sun are well known

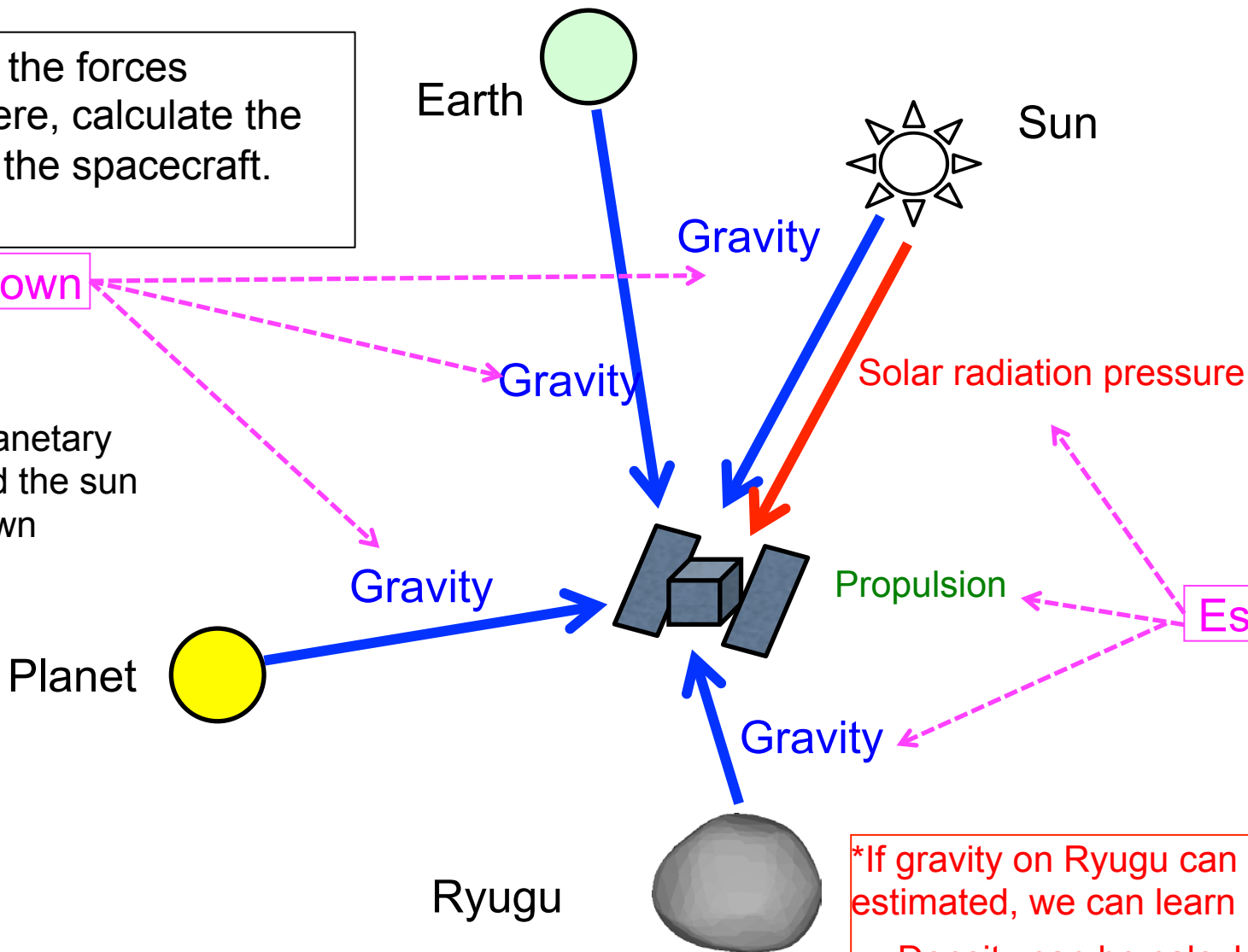

Estimated

*If gravity on Ryugu can be estimated, we can learn its mass.
→ Density can be calculated when volume is known by shape estimation



6. Operations



Tracking stations used in operations



JAXA Sagami-hara Campus

- Telemetry reception, confirmation, analysis
- Command transmission
- Trajectory determination and prediction
- Trajectory planning

(Illustration: Akihiro Ikeshita)

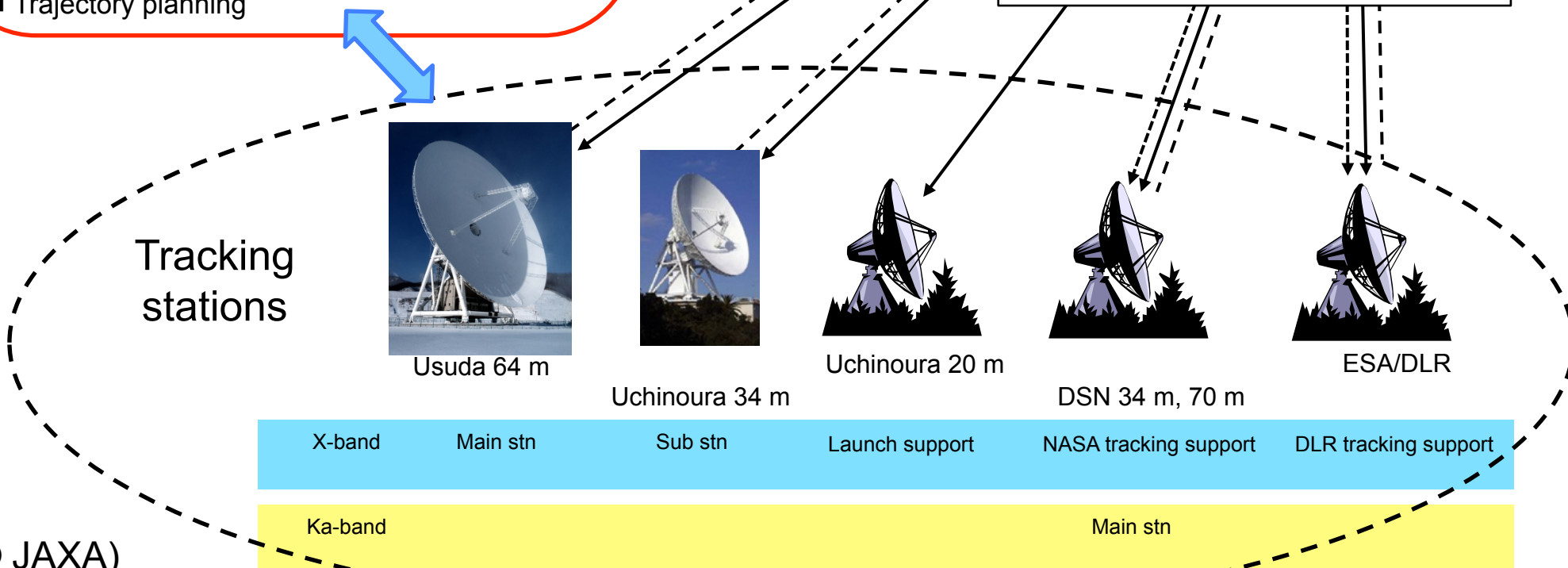
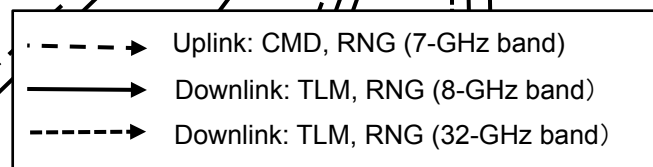



Tracking station locations

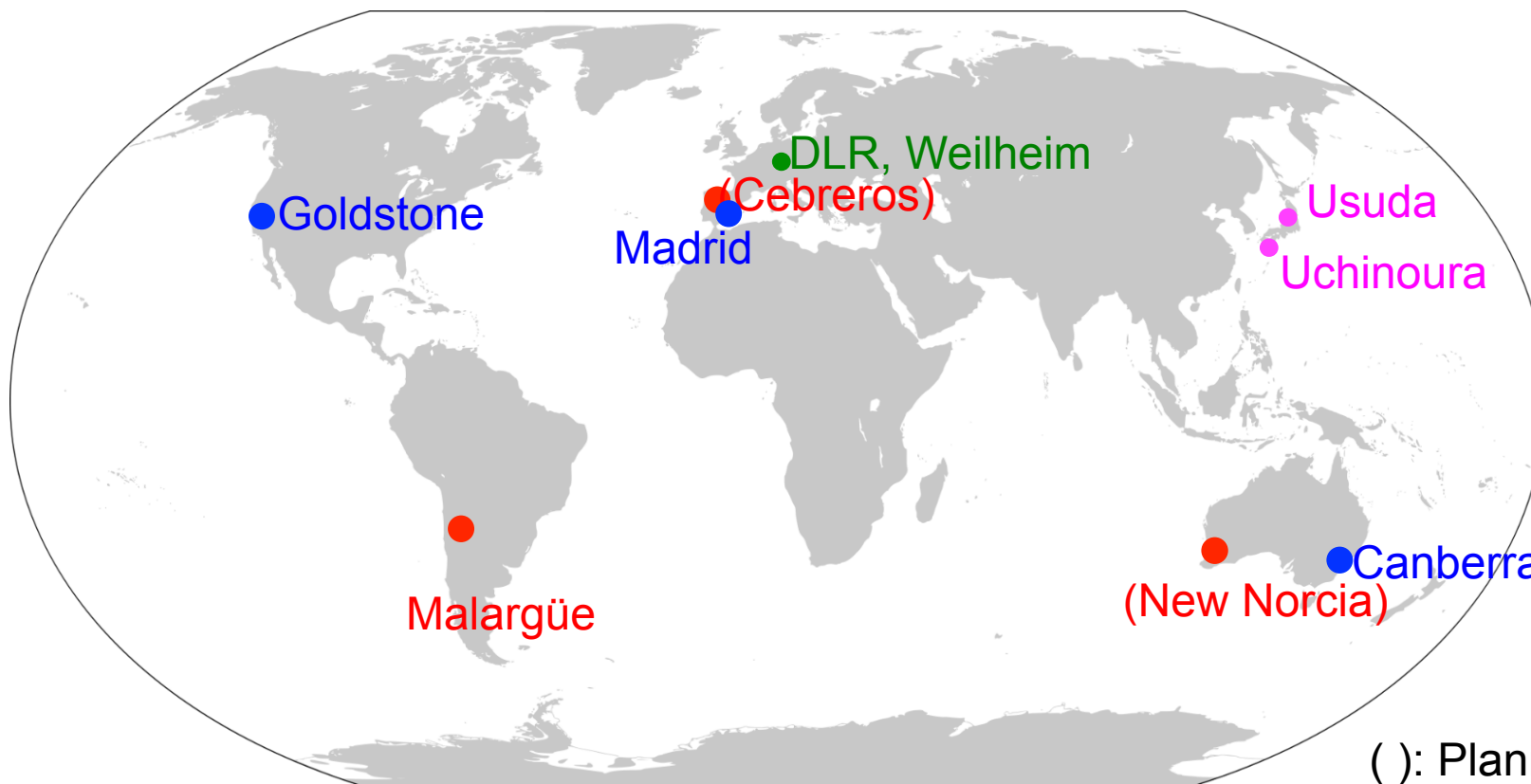

- Usuda is used for normal operations (with Uchinoura also used during launch)
- Critical operations also performed by the NASA Deep Space Network (DSN) (DSN: Goldstone, Madrid, Canberra)
- We are also trying to arrange use of the Weilheim tracking station with support of the German Aerospace Center (DLR) and the European Space Agency Tracking Station Network (ESTRACK) (Malargüe presumed).



Tracking station locations (Part 2)



World map with Japan at center

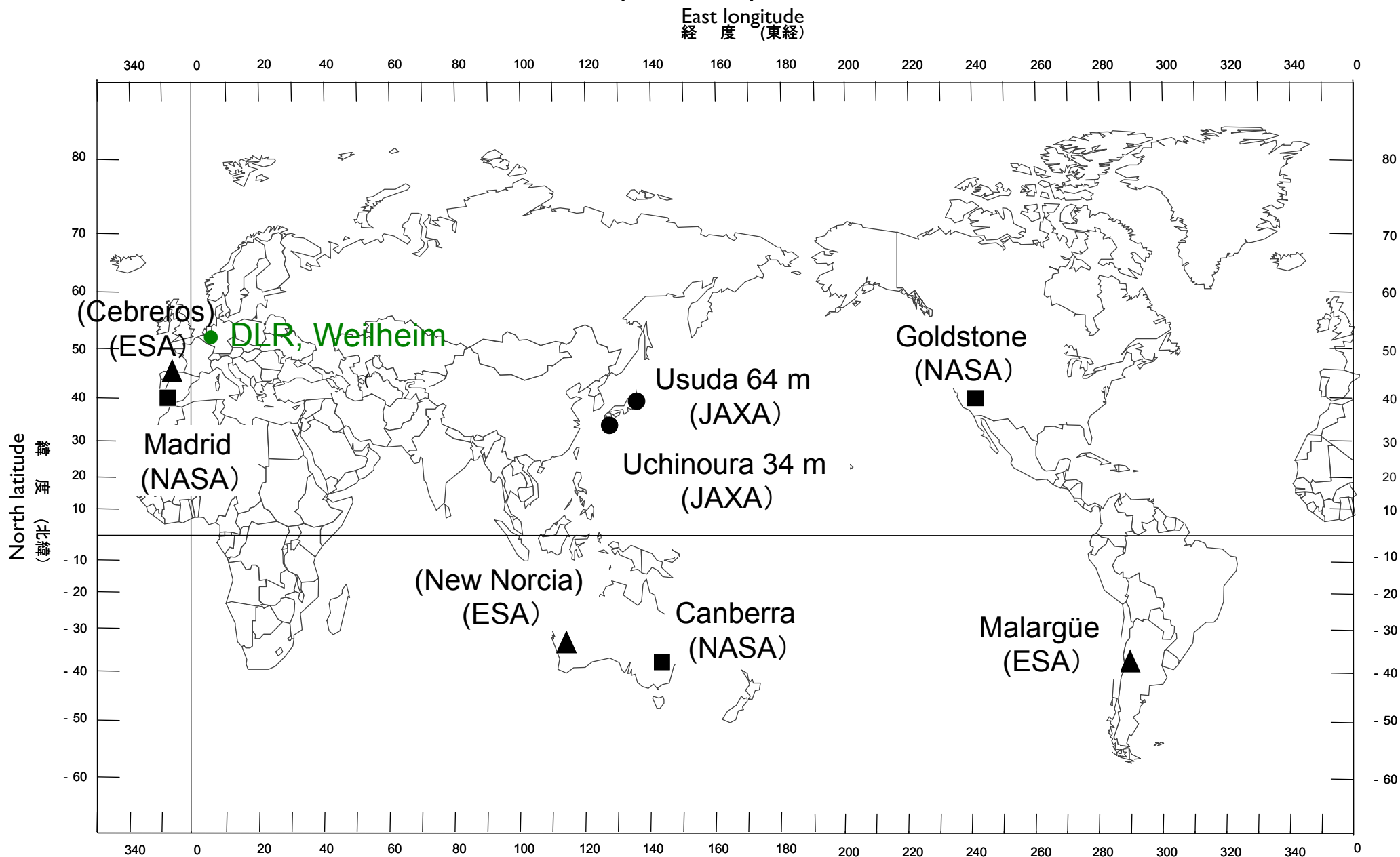

(): Planned usage



Trajectory planning and determination



Spacecraft trajectory operations are conducted under cooperation between the orbit planning group and the orbit determination group.

Trajectory planning

Before launch:

- Plan spacecraft trajectories from launch to Earth return (considering various conditions such as rockets, ion engines, communications, and heat).

After launch:

- Trajectory plans are corrected based on orbit determination values, in particular adjustments to ion engine operations.
- Cooperation with the attitude systems group for trajectories near the asteroid.

Trajectory determination

Before launch:

Confirm precision of trajectory determination from launch to Earth return. Perform analysis presuming data error.

After launch:

- Based on actually acquired data*, estimate spacecraft trajectory (positioning and velocity).
- Attitude systems group supports trajectory estimations for trajectories near the asteroid.

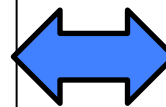



Data used for orbital determination (1/2)

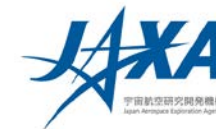

- Normally, range and range rate (Doppler) data are used for spacecraft trajectory determinations.

Range

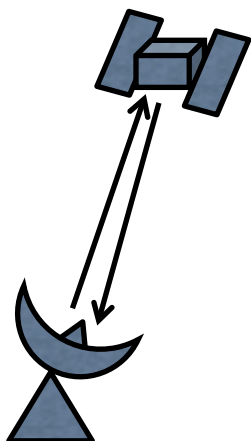

We can know the distance to the spacecraft by sending radio waves from a ground station and measuring the return time of radio waves sent back. This is called the “range.”

Range rate (Doppler)

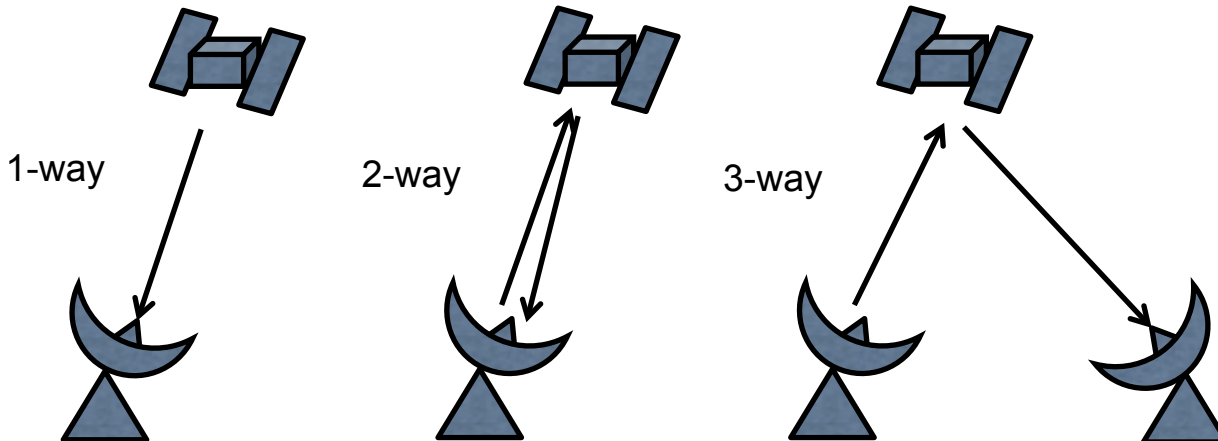

Both the spacecraft and the ground station are moving, so the frequencies of radio waves traveling between them change due to the Doppler effect, like any other wave. In other words, by examining changes in transmitted and received radio wave frequencies, the line-of-sight speed of spacecraft with respect to the ground station can be known. This is called the “range rate” or “Doppler.” Distances can be measured using methods called 1-way, 2-way, or 3-way Doppler.

“Radio navigation” refers to estimating position and velocity (trajectory) of the spacecraft using the range and range rate.



Data used for orbital determination (2/2)



- DDOR: A technique called Delta Differential One-way Ranging is used to more accurately determine trajectories.

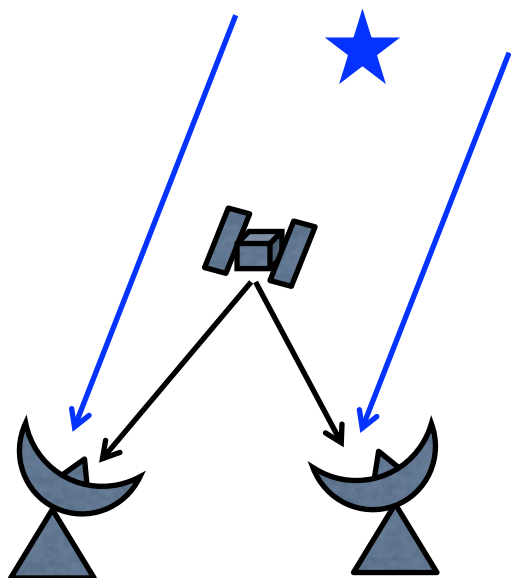

At least two ground stations simultaneously receive radio waves from the spacecraft. In addition, we receive radio waves emitted from a visible celestial body (a quasar) that is visually as close as possible to the spacecraft. By interfering data received at two or more ground stations, the probe trajectory can be determined with high accuracy. (Radio waves from the probe and those from the quasar are received alternately.)

Blue arrows show waves from the quasar

- Optical navigation: Optical navigation, in which data from spacecraft cameras supplement radio navigation, is performed immediately before arrival at the asteroid.

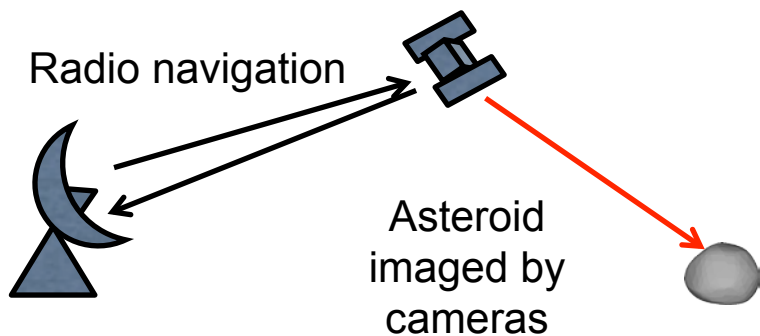

By imaging the asteroid using onboard cameras, we can determine the direction to the asteroid as seen from the spacecraft. The spacecraft position can be accurately determined through DDOR, but uncertainty regarding the asteroid's position remains. Accurately approaching the asteroid while verifying its position from the spacecraft is called optical navigation.



7. Target body



Asteroid Ryugu

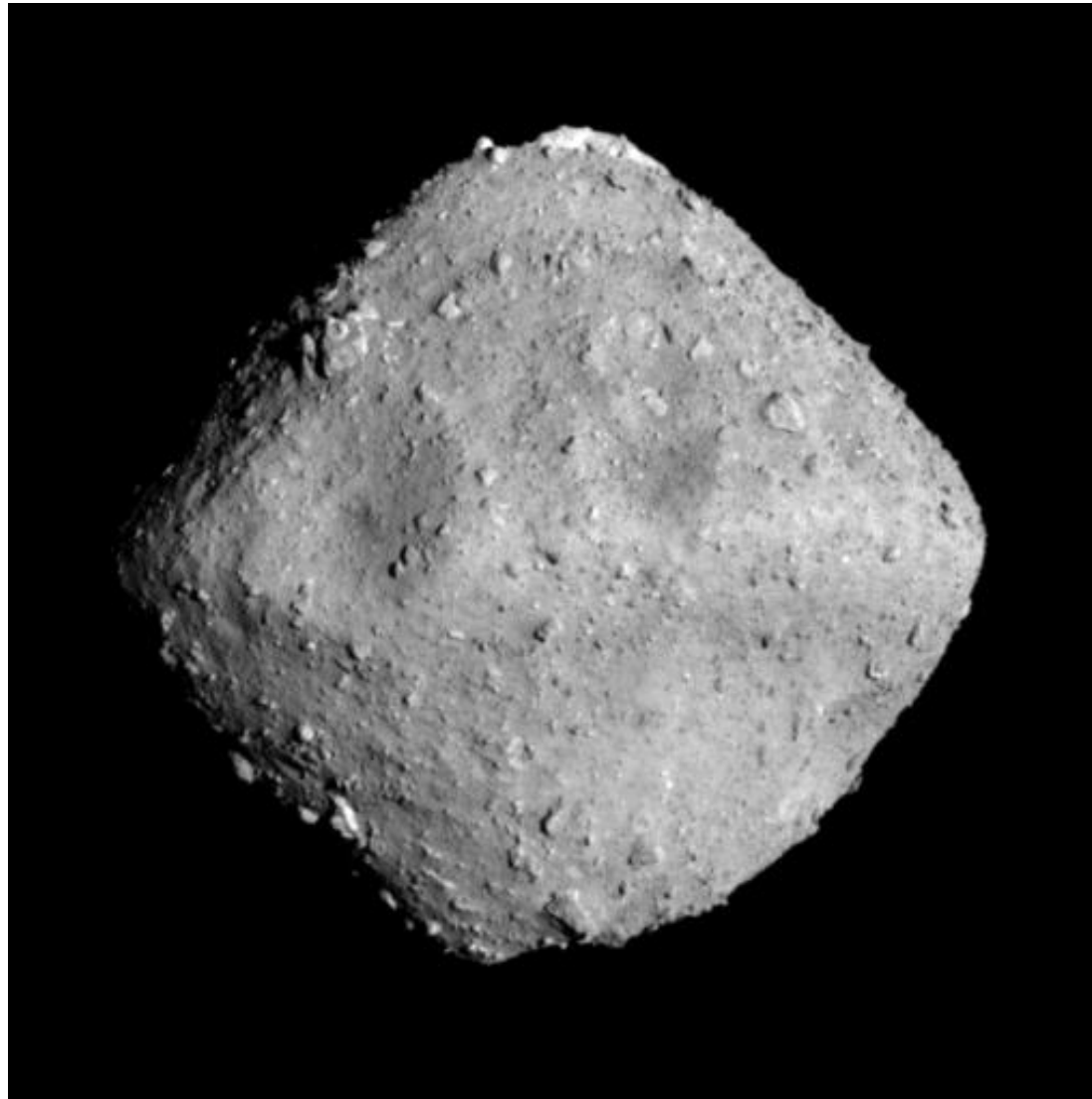

Asteroid Ryugu imaged with the ONC-T. The photograph was taken on June 26, 2018 at around 12:50 JST. The distance to Ryugu is about 22 km.

Image credit : JAXA, University of Tokyo, Kochi University, Rikkyo University, Nagoya University, Chiba Institute of Technology, Meiji University, University of Aizu, AIST.



Asteroid Ryugu



Notice : The data shown here do not include the data obtained by the spacecraft.

- Name : Ryugu
- Permanent designation : 162173
- Provisional designation : 1999 JU₃
- Discovered : May 1999
- Size : Approx. 900 m
- Shape : Nearly spherical
- Rotation period : approx. 7 h 38 min
- Rotation orientation : Ecliptic longitude $\lambda = 310^\circ - 340^\circ$
Ecliptic latitude $\beta = -40^\circ \pm 15^\circ$
- Reflectivity : 0.05 (blackish)
- Type : Type C (assumed to comprise materials containing water and organics)
- Orbital radius : Approx. 180,000,000 km
- Revolution cycle : Approx. 1.3 yr
- Density and mass : Density is currently unknown, but presumed to be 0.5–4.0 g/cm³
: Mass is approx. 1.7×10^{11} kg – 1.4×10^{12} kg.

Orbit of Ryugu



Estimated shape

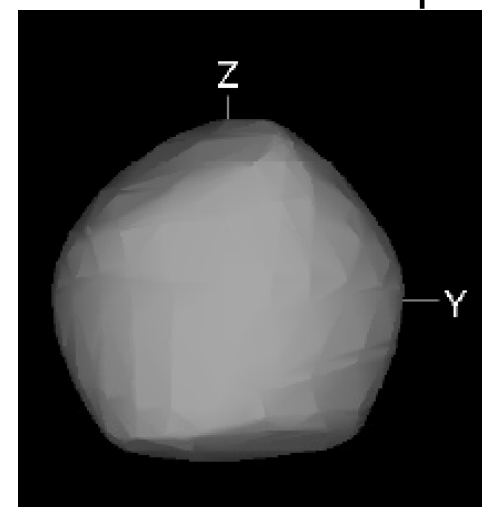

(by T. Mueller)



Asteroid Ryugu (detailed information)



Notice : The data shown here do not include the data obtained by the spacecraft.

162173 Ryugu (1999 JU₃) near-Earth asteroid (Apollo group)

Orbital elements: epoch 2458000.5 TDB (4 Sep 2017 0:00 UTC) JPL Small-Body Database Browser

<https://ssd.jpl.nasa.gov/sbdb.cgi#top>, accessed 10 Dec 2017

- Semi-major axis 1.18956 au; eccentricity: 0.19028; inclination: 5.8839°
- Ascending node long.: 251.591°; argument of perihelion: 211.447°; perihelion passage: 13 Feb 2017. 25148
- Period: 473.8908 days = 1.29747 yr
- Perihelion distance: 0.96321 au; aphelion distance: 1.41592 au
- Minimum orbit intersection distance: 0.00112 au (potentially dangerous asteroid)

Physical parameters

- Rotation period: 7.6326 h; ecliptic longitude (λ) $325 \pm 15^\circ$ ecliptic latitude (β) $-40 \pm 15^\circ$
- Thermal inertia: 150—300 J m⁻² s^{-1/2} K⁻¹, extremely low surface roughness [Müller+ 2017]
- Mean geometric radius: 865 ± 15 m, nearly spherical [Müller+ 2017]
- Albedo: geometric 0.047±0.003, Bond 0.014±0.002 [Ishiguro+ 2014]
- Spectral type: Cg [Binzel+ 2001]. The reflection spectrum gradient is nearly flat, but slightly reddened in the near-infrared region and with a slight drop in the ultraviolet region. This resembles the reflection spectra of CM and CI meteorites that have experienced heating. [Perna+ 2017]

(TDB: In solar system dynamics, 1 au = 1.49598×10¹¹ m)



Size comparison between Ryugu and Itokawa

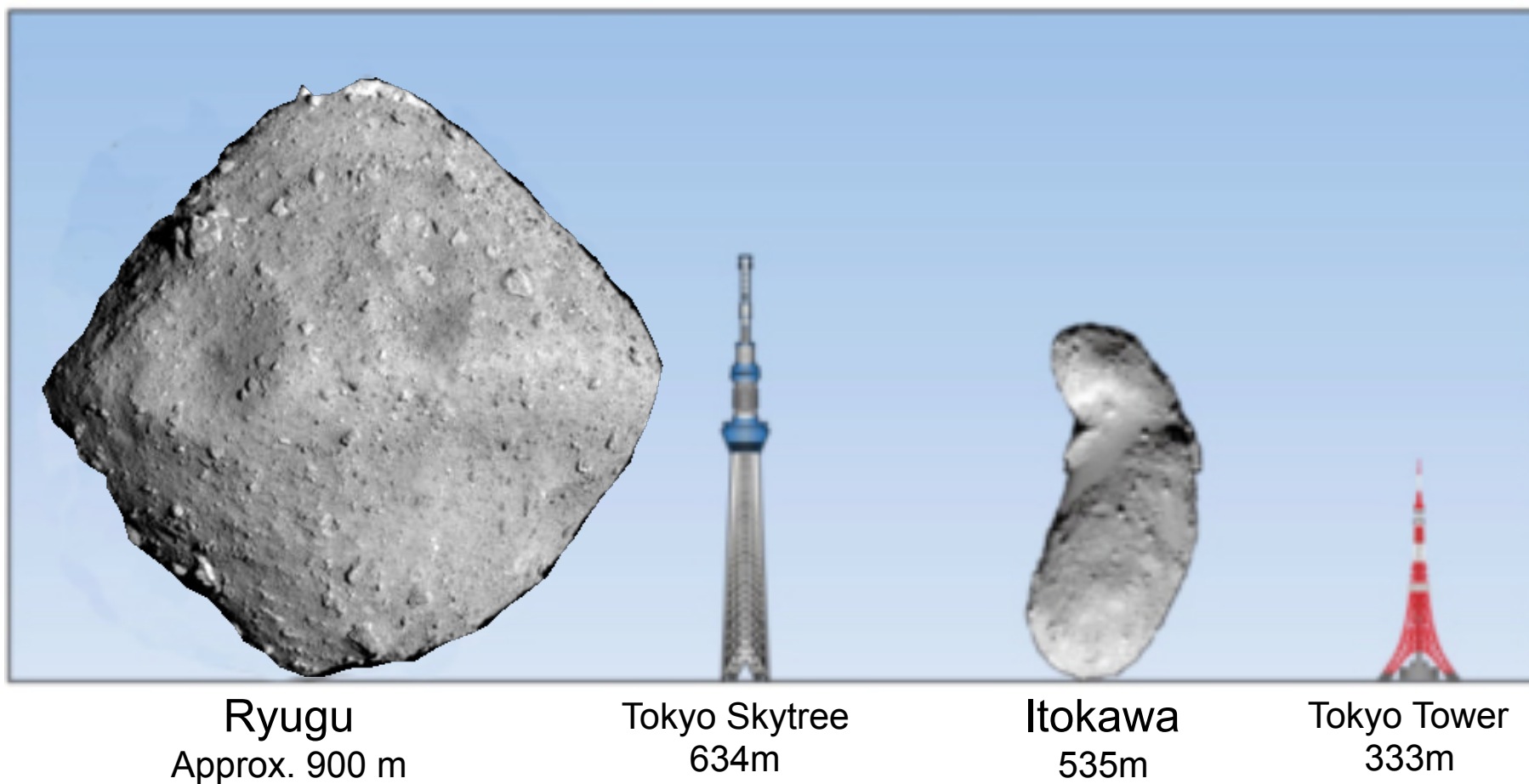



(162173) 1999 JU₃ (Ryugu) spectrum

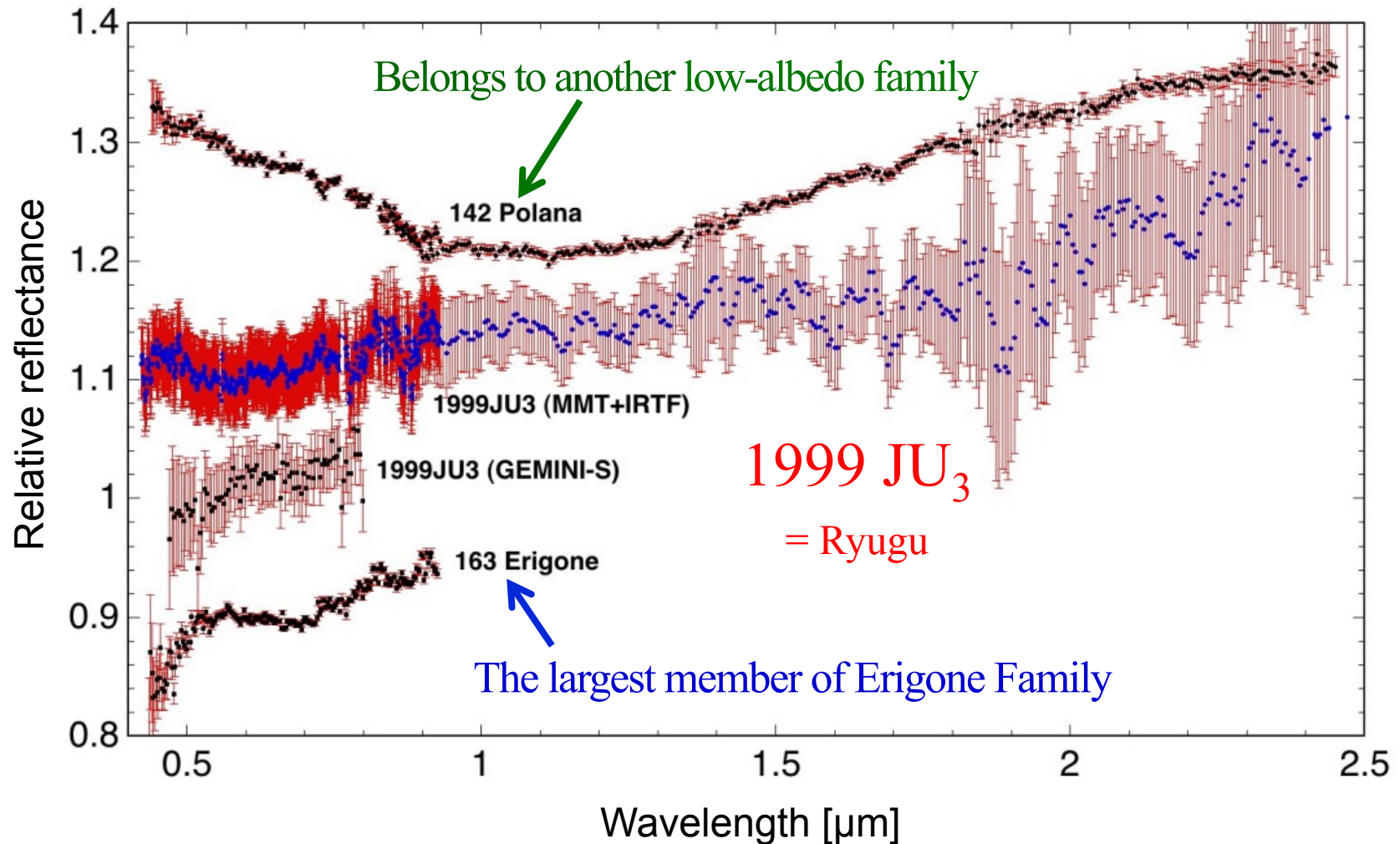

(Data from Viras (2008), Sugita et al. (2012), Abe et al. (2008))



(162173) 1999 JU₃ (Ryugu) light curve

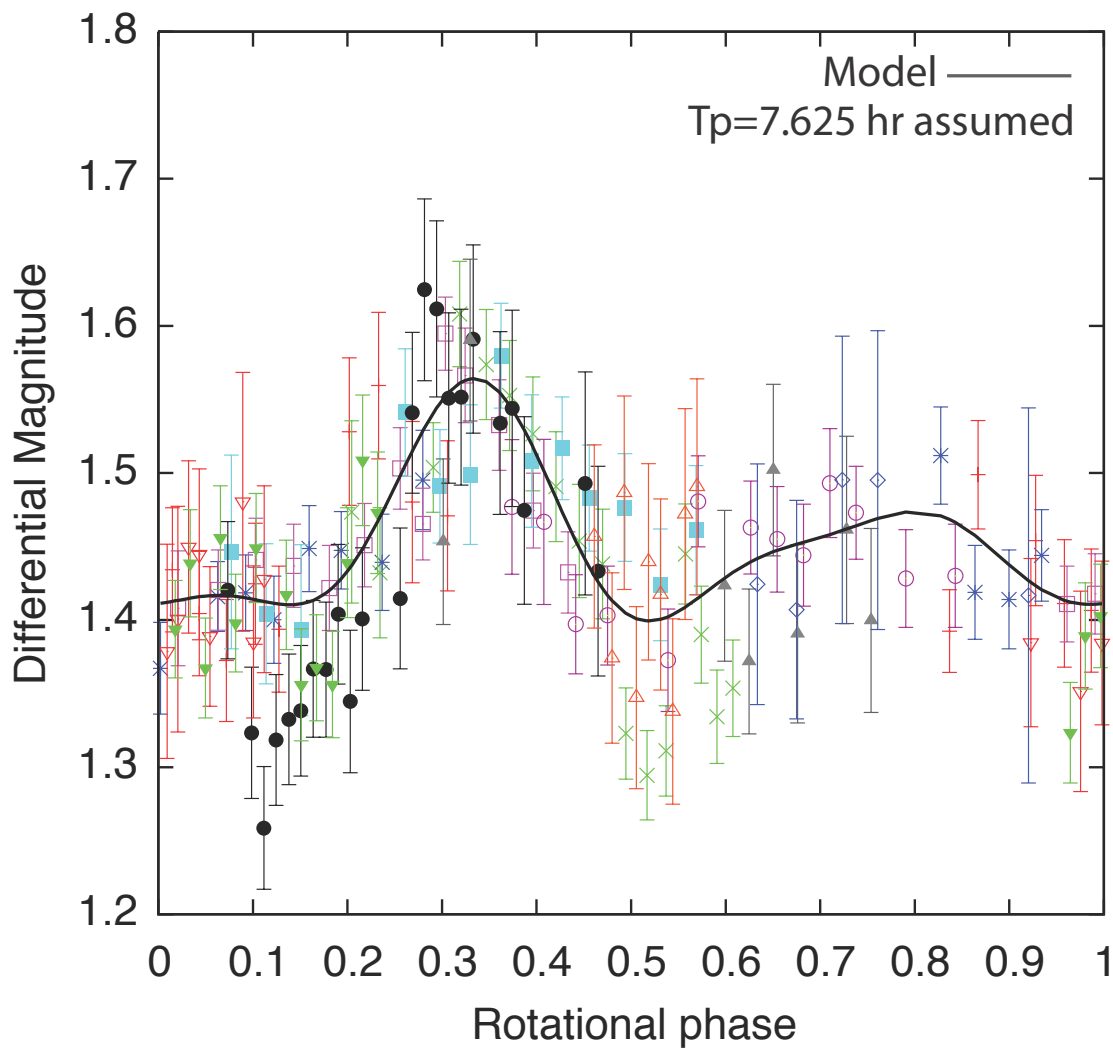
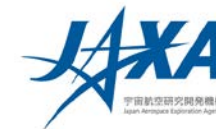

(from Kim, Choi, Moon et al. A&A 550, L11 (2013))



History of Ryugu naming



- 10 May 1999: U.S. LINEAR team discovers asteroid 1999 JU₃ (provisional name) at the Socorro observatory.
- Oct 2006: 1999 JU₃ is listed as a candidate exploration target in the “Hayabusa Successor Spacecraft” proposal.
- Aug 2013: Request for naming 1999 JU₃ in the Hayabusa 2 project submitted to the LINEAR team, and approval received.
- 22 Jul–31 Aug 2015: A campaign for collecting proposed names is conducted. Approximately 7,300 suggestions are received, from which “Ryugu” is selected.
- Sep 2015: LINEAR team submits the name “Ryugu” to the International Astronomical Union.
- 28 Sep 2015: Ryugu is published in the Minor Planet Circulars as (162173) Ryugu = 1999 JU₃.



Selection of asteroids for exploration



Conditions for selecting an asteroid for exploration:

- Scientific objectives
In the Hayabusa 2 project, a C-type asteroid
- Engineering requirements
Ability to return within Hayabusa 2 capabilities
→ Limits on trajectory size and inclination
Ability for touchdown within Hayabusa 2 capabilities
→ Limits on asteroid size and revolution period

Explorable asteroids

- Orbit between those of Earth and Mars, low inclination from Earth orbit (From spacecraft trajectory control capabilities)
- Revolution period of at least about 6 hours (From navigational capabilities at touchdown)
- Diameter of at least several hundred meters (To allow for crater creation by impactor)

Note: We also searched for backup targets, but only 1999 JU₃/Ryugu was found to be appropriate.



Required acceleration from Earth to asteroid and asteroid absolute magnitude

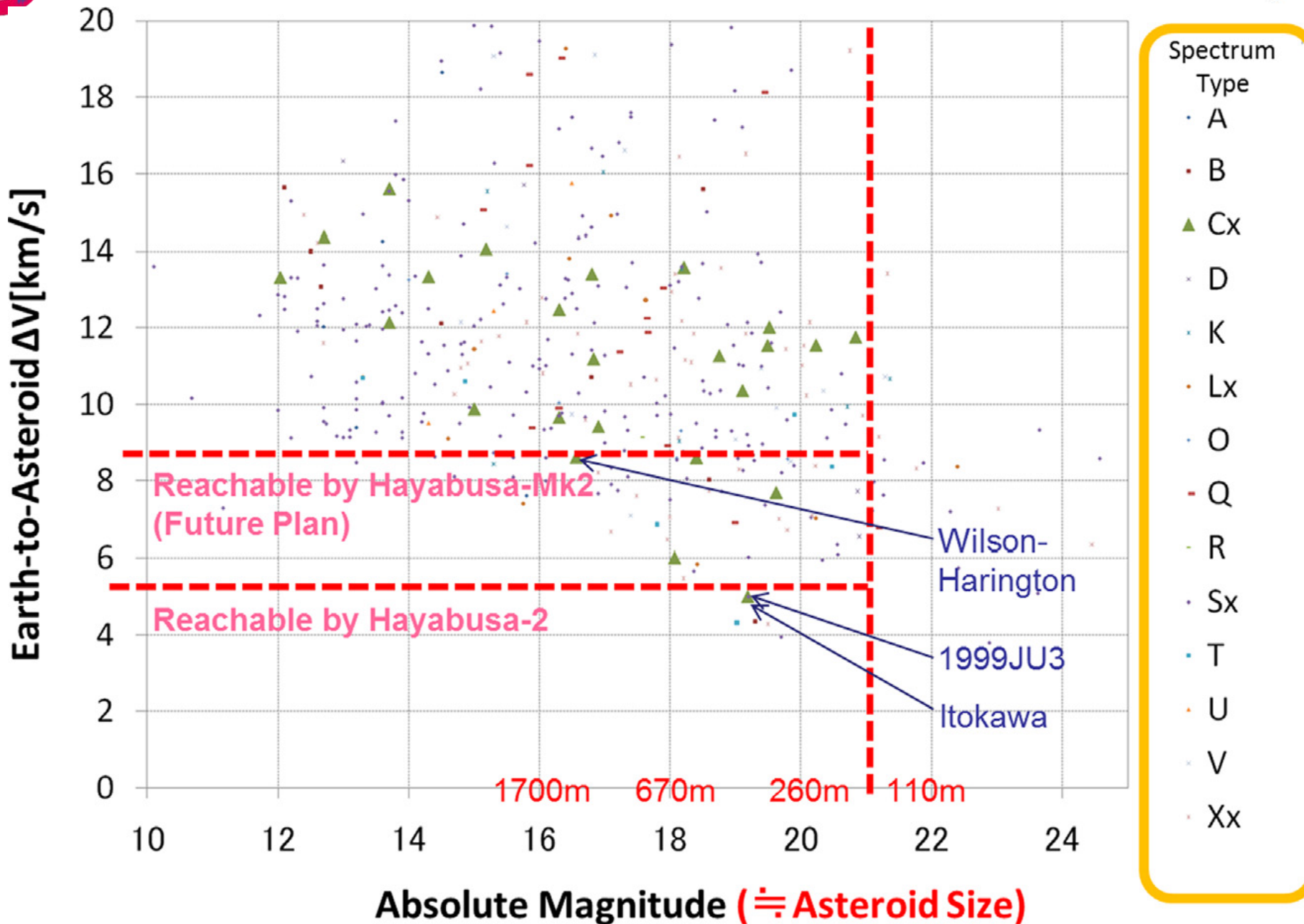



Reference information



Categorization by asteroid spectral type

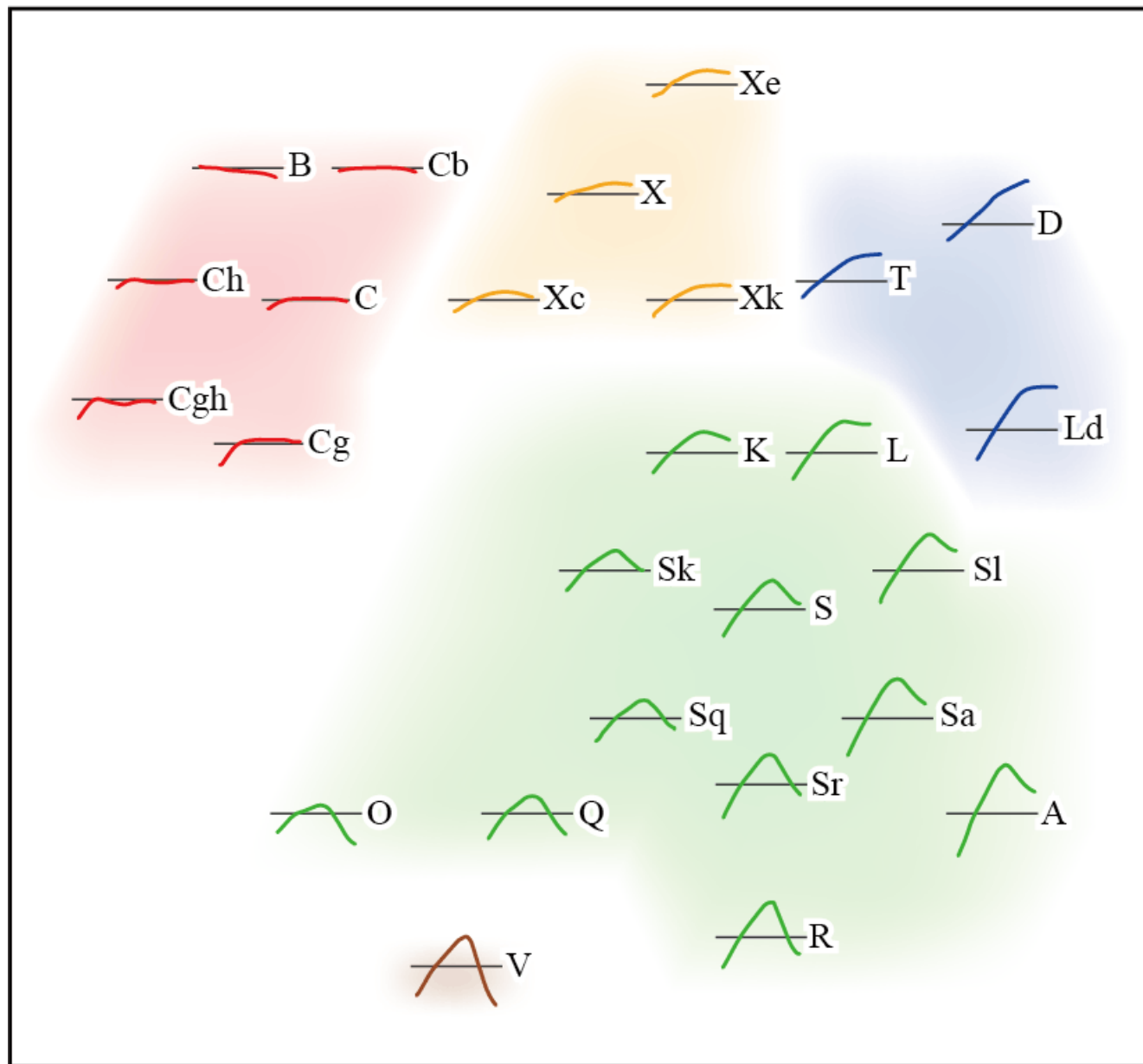

Adapted by Usui from Bus & Binzel (2002)



Classification and ratios of asteroid types



Classification of asteroids by reflective spectrum

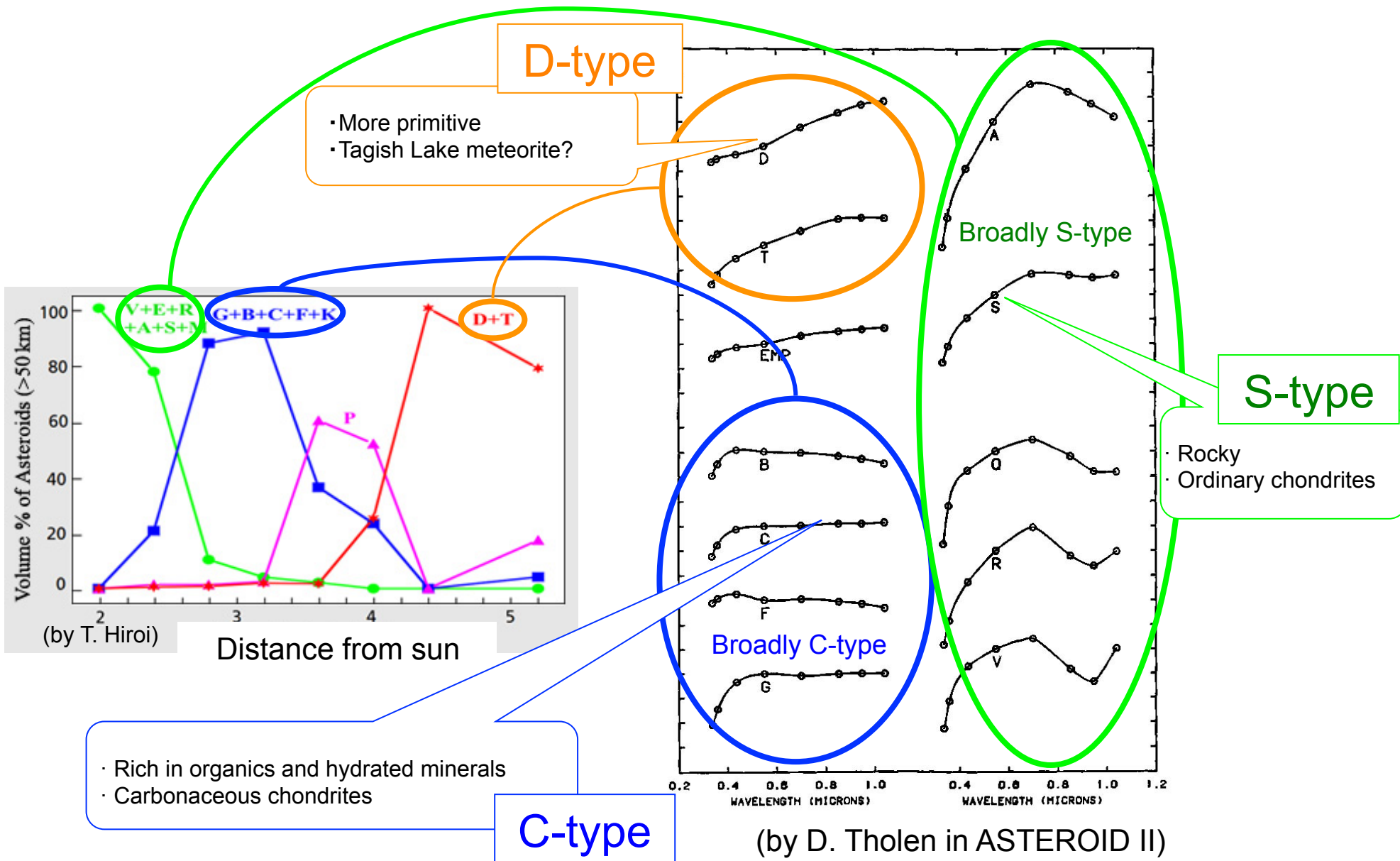



Features of each type (1/2)



Type	Spectral form	Distribution	Correlation with meteorites
C	Flat from 0.45–0.9 μm . Absorption of hydrous mineral origins in 3- μm band in most cases.	Often outside of the asteroid belt.	Carbonaceous chondrites
S	Reflectance increases from 0.4 to 0.7 μm , but decreases to 0.7 to 0.9 μm . There is an absorption band around 0.8–1.4 μm and 2 μm . This is consistent with the absorption bands of pyroxene and olivine.	Often outside of the asteroid belt.	Ordinary chondrites However, reflectance on the short wavelength side is lowered due to space weathering.

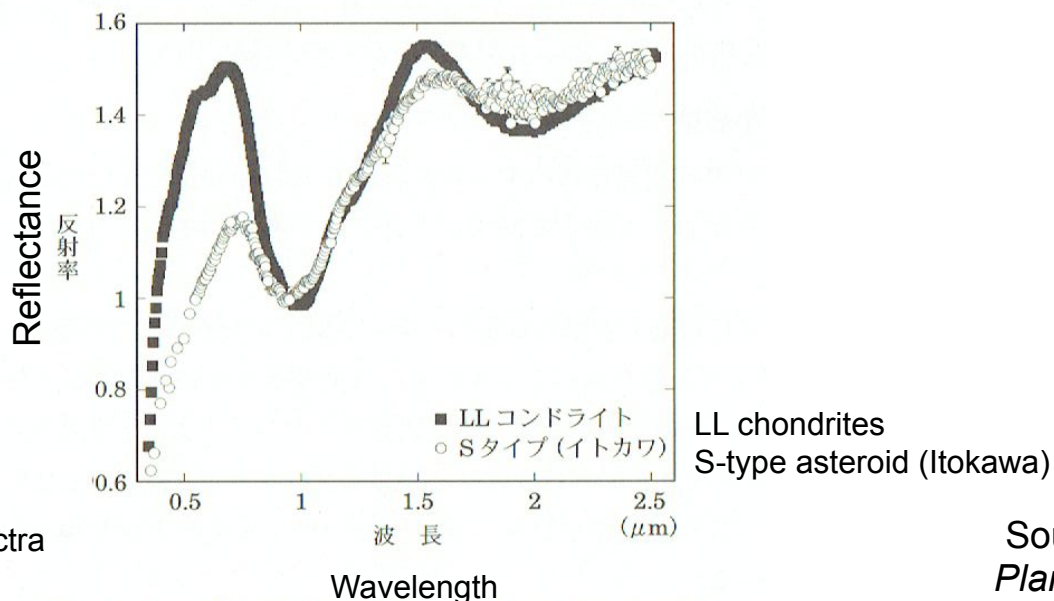

Fig. 5.7: Comparison of spectra from S-type asteroids and ordinary chondrites

図 5.7 S タイプ小惑星と普通コンドライトのスペクトルの比較.

Source: *The Solar System and its Planets*, Nippon Hyoronsha



Features of each type (2/2)

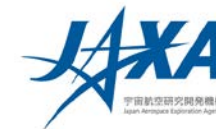

Type	Spectral form	Distribution	Correlation with meteorites
X	<p>Reflectivity gently increases at 0.4–0.9 μm.</p> <p>Those with low reflectance of -0.04 at 0.55 μm are also called P-type.</p> <p>M-type have reflectance of -0.1.</p> <p>E-type have reflectance of -0.4.</p>	Exist throughout the asteroid belt	<p>Iron meteorite</p> <p>Metamorphic Tagish Lake meteorite</p> <p>Enstatite chondrites</p> <p>Achondrite</p> <p>Aubrite</p>
D	Reflectance sharply increases at 0.45–0.9 μm .	Near the Jupiter Trojans	Tagish Lake meteorite
V	<p>Reflectance increases at 0.4–0.7 μm, and abruptly drops at 0.7–0.9 μm.</p> <p>Absorption bands are observed around 0.8–1.4 μm and 2 μm (absorption bands of pyroxene).</p>	Several percent of asteroids in the asteroid belt	Similar to HED meteorites, which are basaltic meteorites. Asteroid Vesta origin?



Meteorite classifications



Frequency on Earth

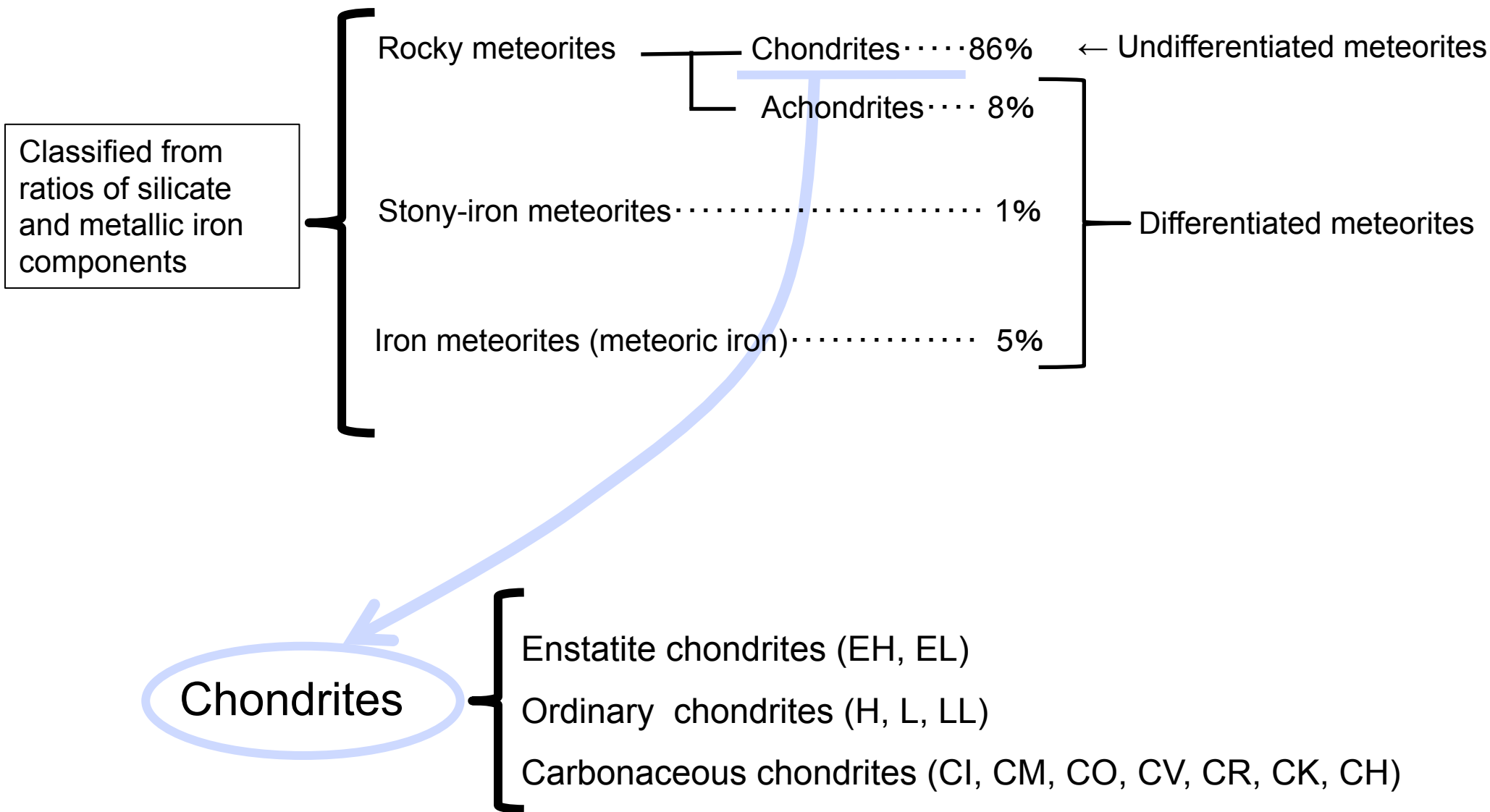



Classification of Meteorites

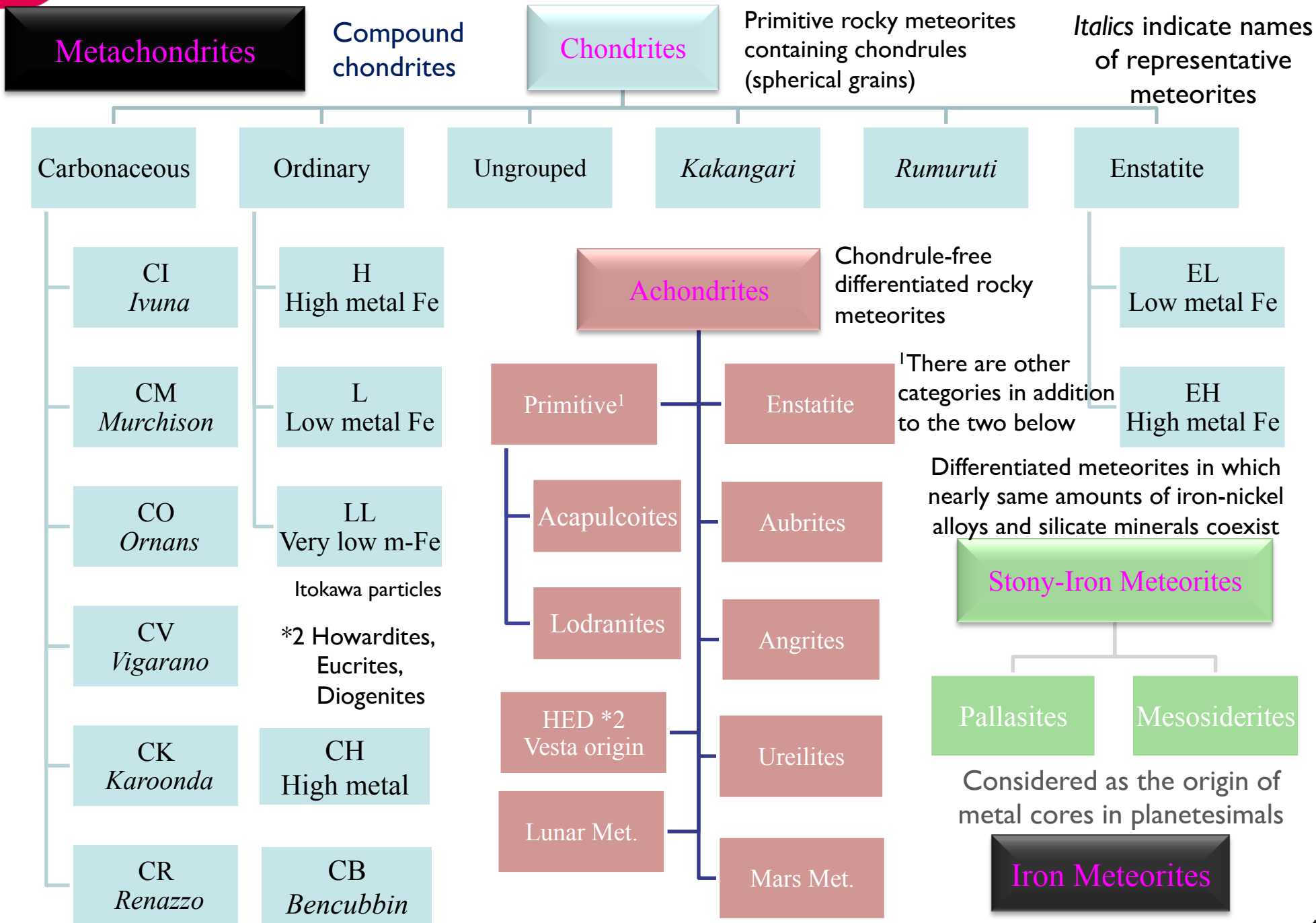



Asteroid naming



- Asteroid discoverer receives naming rights.
- Here, “discoverer” means the person making first observations allowing for estimation of orbit.
- When asteroids are discovered, they are assigned a provisional name.
- After a number of observations allowing for sufficiently precise determination of orbit, asteroids are assigned a permanent designation.
- Names can be proposed after a permanent designation is assigned.
- Proposed names are approved by the International Astronomical Union’s Committee on Small Body Nomenclature.

Naming requirements:

- A pronounceable (preferably single) word of 16 or fewer characters
- Names from political or military events or persons allowed only 100 years after occurrence (for persons, 100 years after death)
- Pet names are not allowed
- Restrictions on names of asteroids in special orbits
- Names similar to those of existing celestial bodies are not allowed
- Names for advertising or commercial purposes are not allowed



Asteroid provisional names



1999 JU₃

Year of discovery

Month of discovery

Order of discovery

Month of discovery

Order of discovery

Char.	Date	Char.	Date
A	Jan. 1–15	B	Jan. 16–31
C	Feb. 1–15	D	Feb. 16–29
E	Mar. 1–15	F	Mar. 16–31
G	Apr. 1–15	H	Apr. 16–30
J	May 1–15	K	May 16–31
L	June 1–15	M	June 16–30
N	July 1–15	O	July 16–31
P	Aug. 1–15	Q	Aug. 16–31
R	Sep. 1–15	S	Sep. 16–30
T	Oct. 1–15	U	Oct. 16–31
V	Nov. 1–15	W	Nov. 16–30
X	Dec. 1–15	Y	Dec. 16–31

A = 1st	B = 2nd	C = 3rd
D = 4th	E = 5th	F = 6th
G = 7th	H = 8th	J = 9th
K = 10th	L = 11th	M = 12th
N = 13th	O = 14th	P = 15th
Q = 16th	R = 17th	S = 18th
T = 19th	U = 20th	V = 21st
W = 22nd	X = 23rd	Y = 24th
Z = 25th		

Note: 26th discovery is A₁, 27th is B₁, 51st is A₂, etc.

Note: "I" is not used

Note: Subscripts are not used when illegibility would result, or typesetting does not allow



8. Science



Science from an asteroid sample return

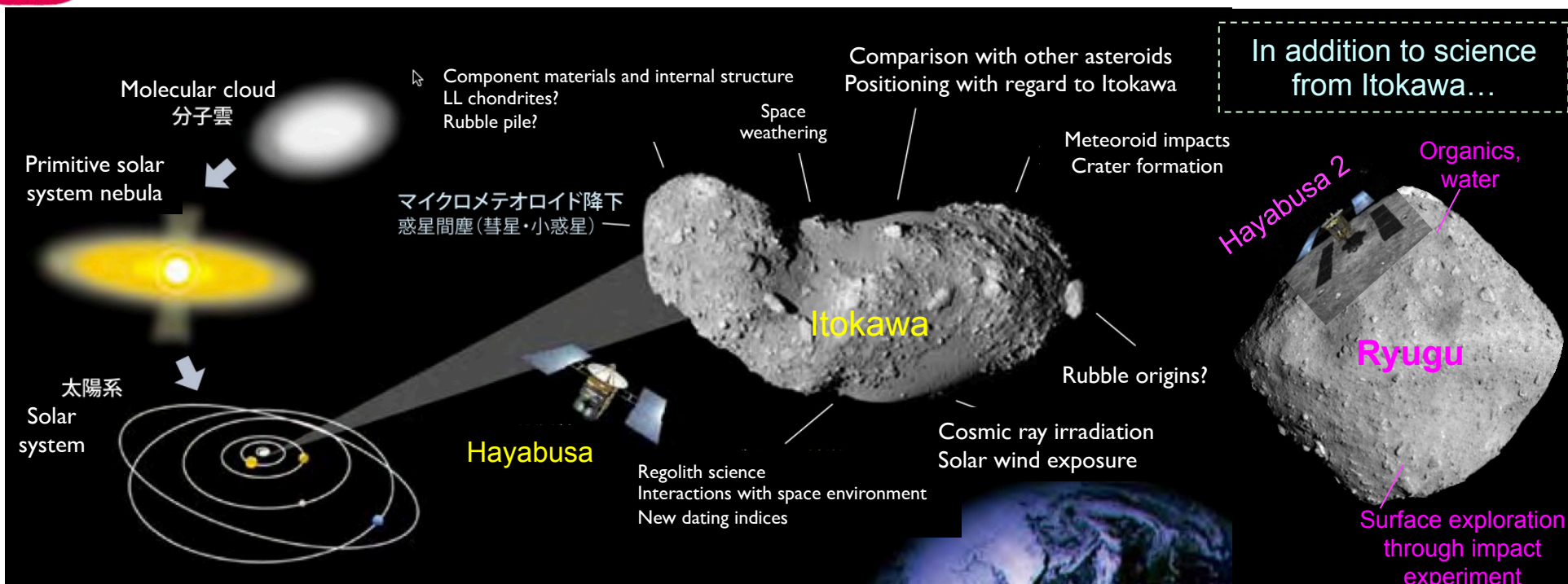

In addition to science from Itokawa...

Solar system's past

- Elucidating the birth and evolution of the solar system
 - What substances existed, and in what state?
 - How did the planets arise and evolve?
 - What were the raw materials (organic matter, water) for life?

Solar system's present

- Calibration of meteorites
 - How are meteorites and asteroid samples related?

Note: Many meteorites have been collected, but they are contaminated by the Earth's atmosphere, water, etc., making it difficult to determine their situation when they were in space. Through comparisons with asteroids, meteorites can become valuable samples.



Science: Elucidating the birth and evolution of the solar system



Topics

① Investigating the materials that formed the planets

What materials existed in the primitive solar system disk, and how did they change up to the formation of planets?

② Investigating the formation processes of the planets

How do celestial bodies grow from planetoids to planets?

(© JAXA)

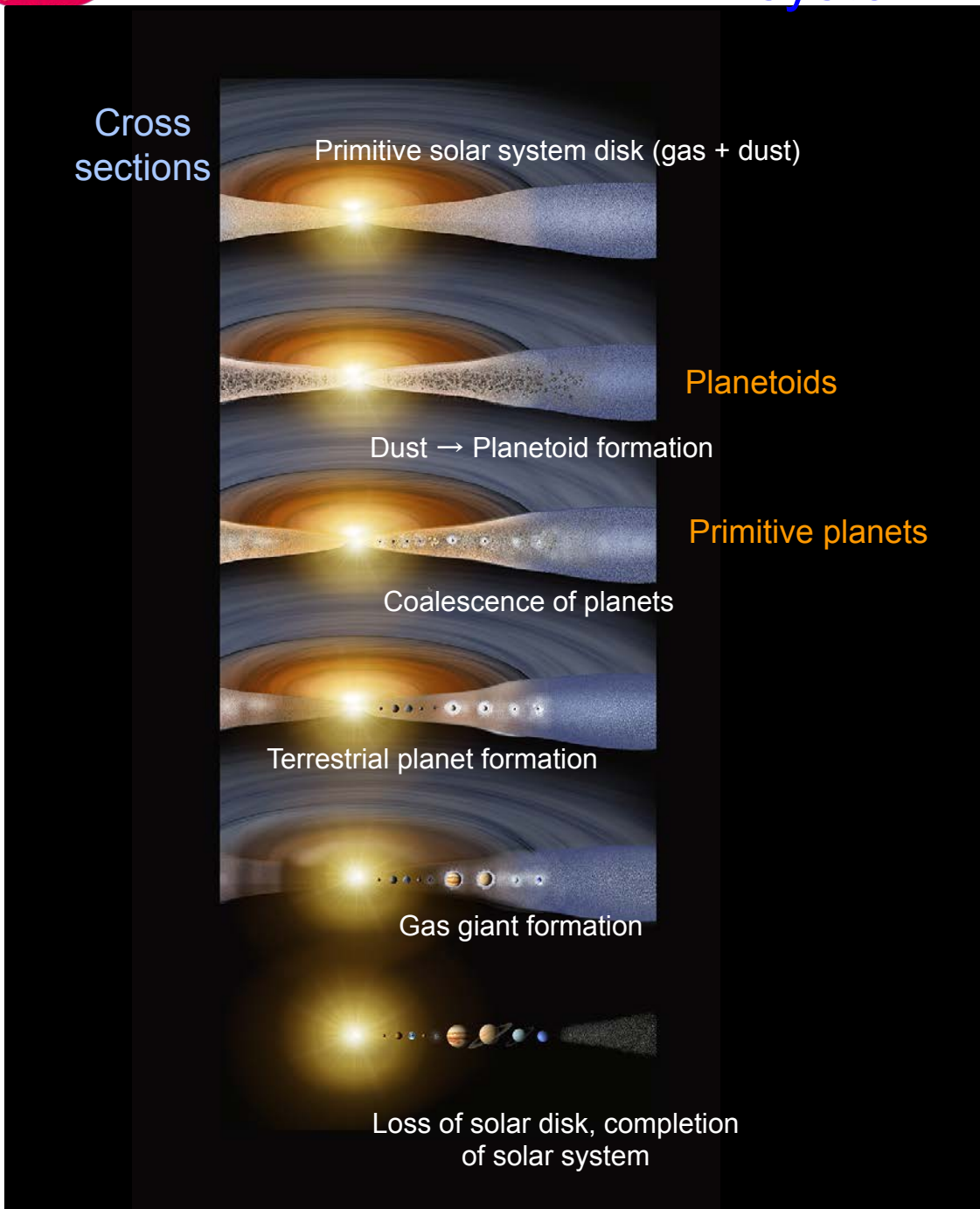



① Investigating the materials that formed the planets

- The universe is thought to have been created 13.8 billion years ago. Following that, stellar evolution produced various elements, which were scattered into space. The solar system was formed from these materials approximately 4.6 billion years ago, but the materials that were present in space at that time remain unknown.
- We will clarify the distribution of substances in the original solar system disk.
- We will clarify how these substances changed on celestial bodies after their initial formation.



Finally, we will elucidate the materials that formed the planets, oceans, and life.

Keywords:

- **Pre-solar particles**: Particles from the interstellar molecular cloud brought into the solar system
- **Calcium–aluminum-rich inclusions (CAI)**: Substances that record high-temperature states in the early solar system
- **Interactions between minerals, water, and organics**: Diversification of organic matter on early celestial bodies
- **Thermal metamorphism, space weathering**: Material changes occurring within or on the surface of celestial bodies after their formation



Elucidation of organics by Hayabusa2



Volatile substances, such as water and organic matter, form on dust surfaces in molecular clouds. It is thought that these change due to aqueous metamorphism and thermal denaturation in primitive solar system discs and planetoids, eventually accumulating on Earth and providing materials for life. We will clarify what kinds of substance existed during this process.

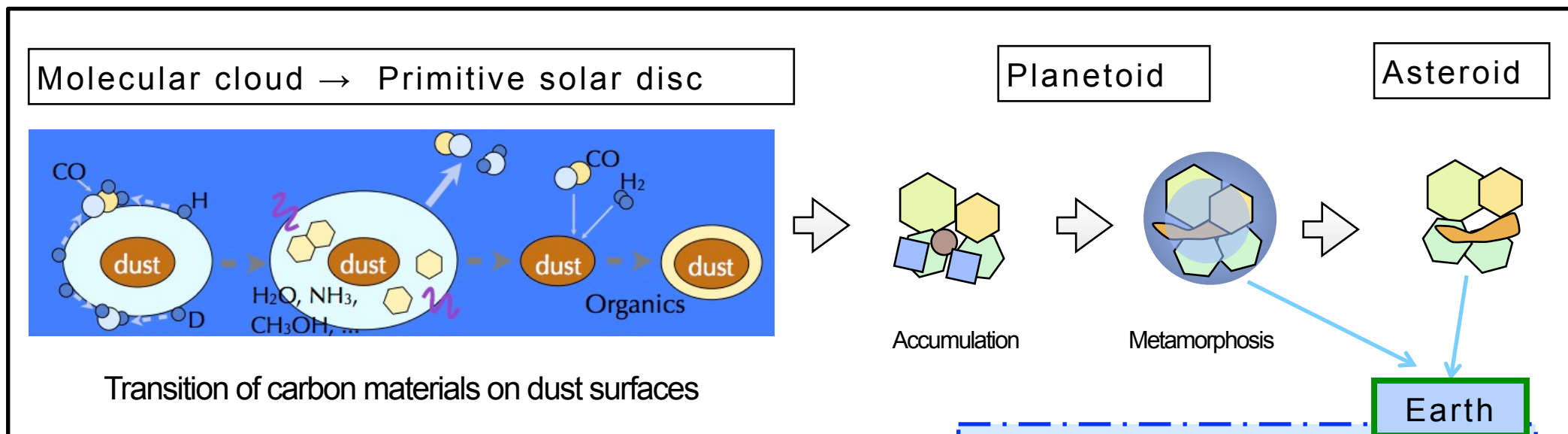

Interactions between materials, water, and organics

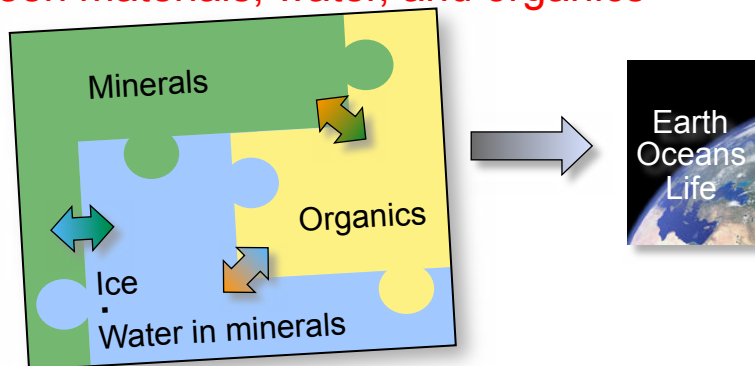

Chirality of amino acids

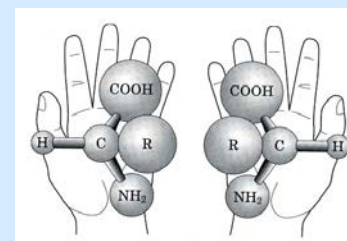

Left-handed (L-configuration) and right-handed (D-configuration) amino acids

Life on Earth almost exclusively uses left-handed amino acids. But why?



Reference: Molecules containing carbon found in space

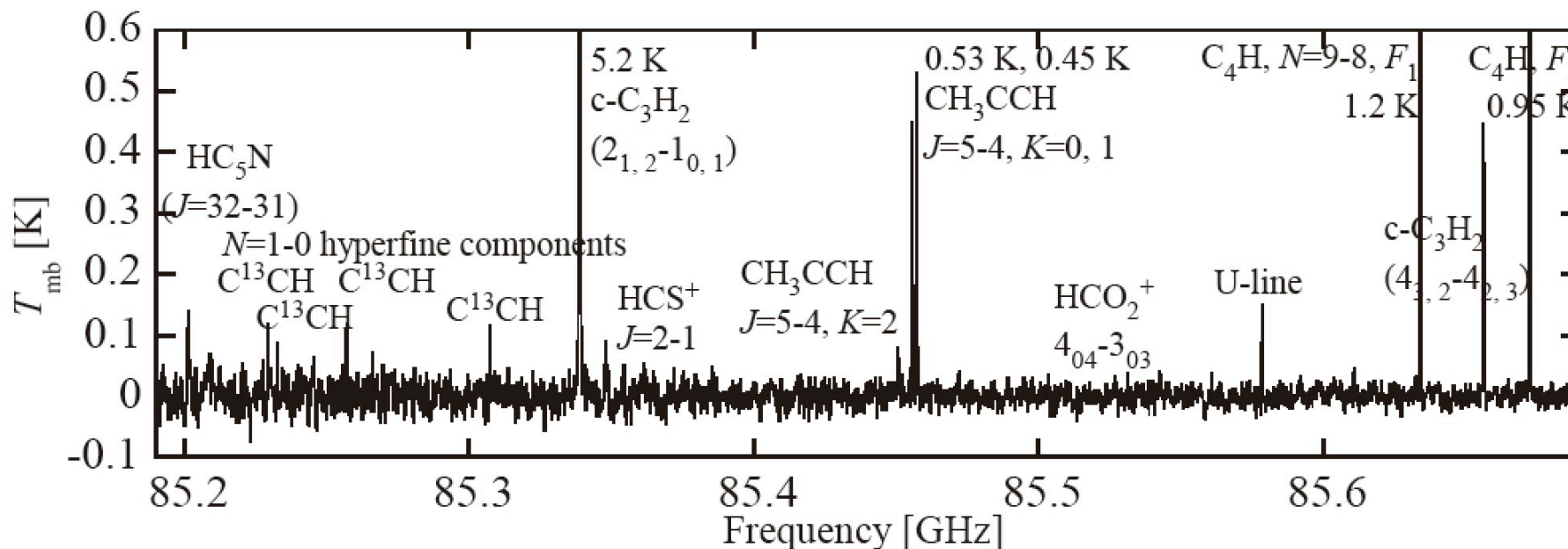

(From Sakai (2011), *Yuseijin*)



Topics for Hayabusa 2

What kind of organics were present in the primitive solar disc before the creation of Earth?



② Investigating planetary formation

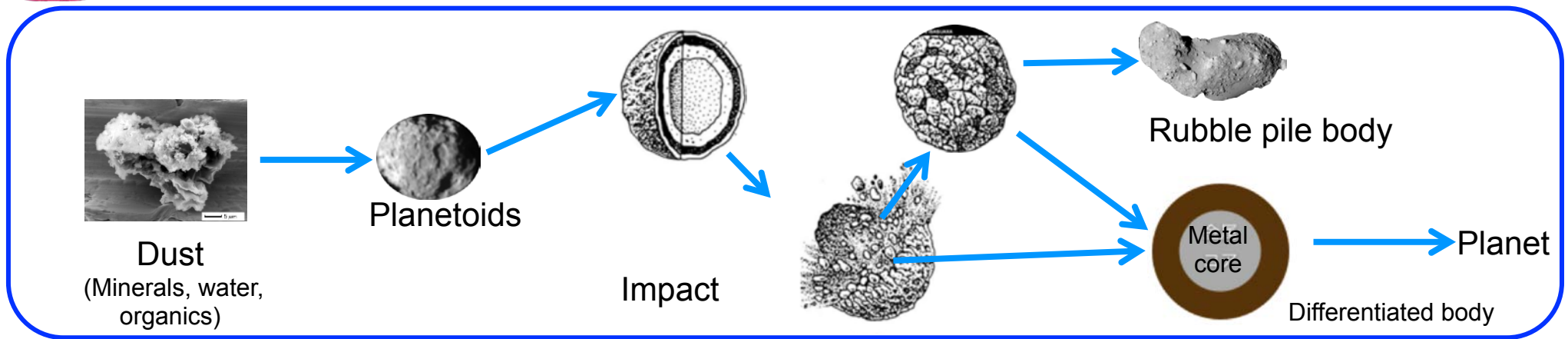

- Elucidate the structure of planetoids that eventually became planets.
- Elucidate what processes occurred during the collisions, coalescence, and accumulation of celestial bodies.



Elucidate formation processes from planetoid to planet

Keywords:

- **Rubble pile body**: A celestial body formed from accumulated rubble
- **Impacts and coalescence**: When celestial bodies collide, the resulting fragments can combine to form a new body
- **Accumulation**: Accumulation of fragments resulting from a collision via the force of gravity



Reference: History of the sun, planets, and Earth



Hayabusa & Hayabusa2

We will investigate events in the early solar system as recorded in asteroids, thereby elucidating the process by which planets formed.

Elucidation of the Missing Zone

Sun
Planetoids

Earth

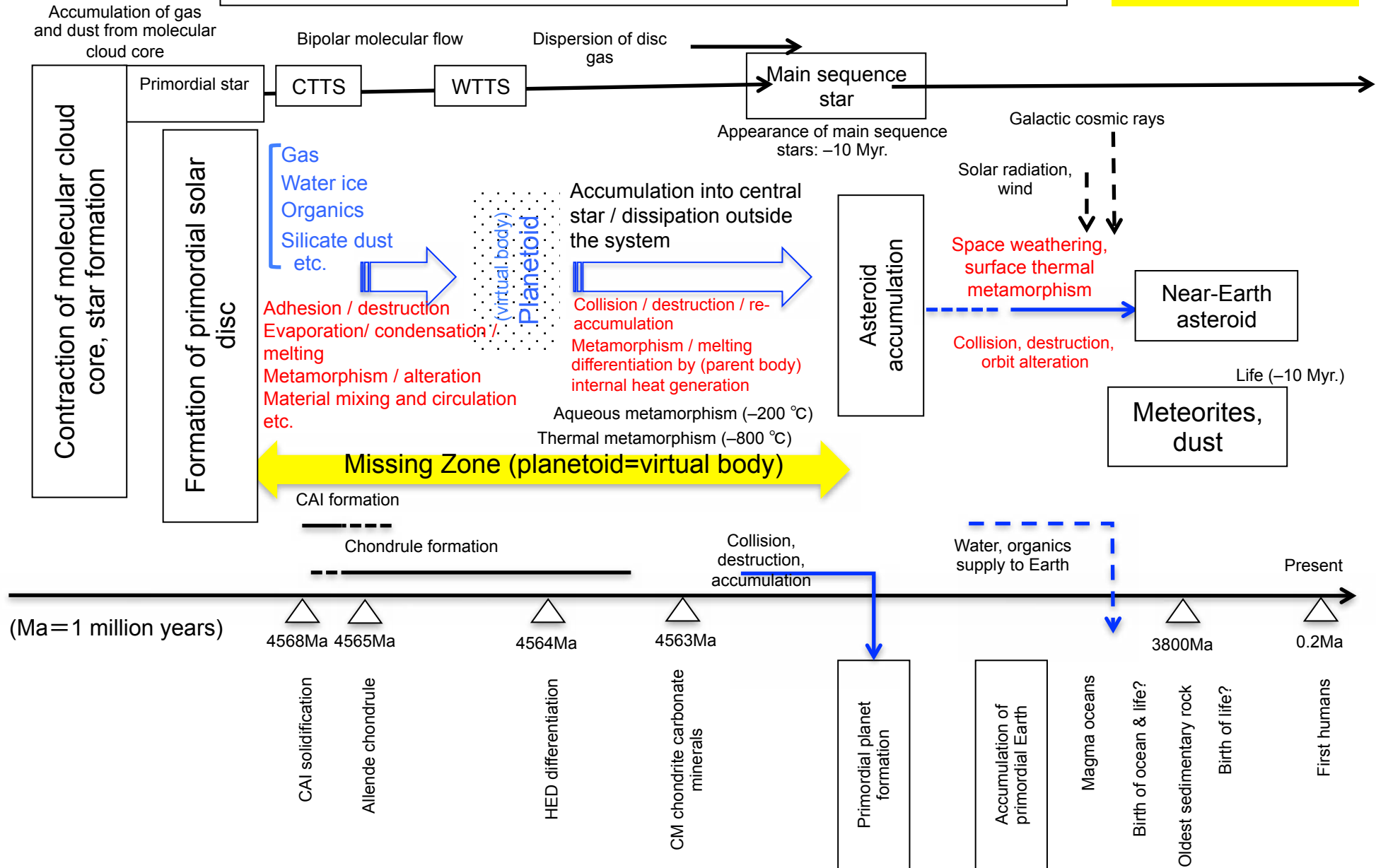



9. International cooperation



Overview of international cooperation for Hayabusa 2

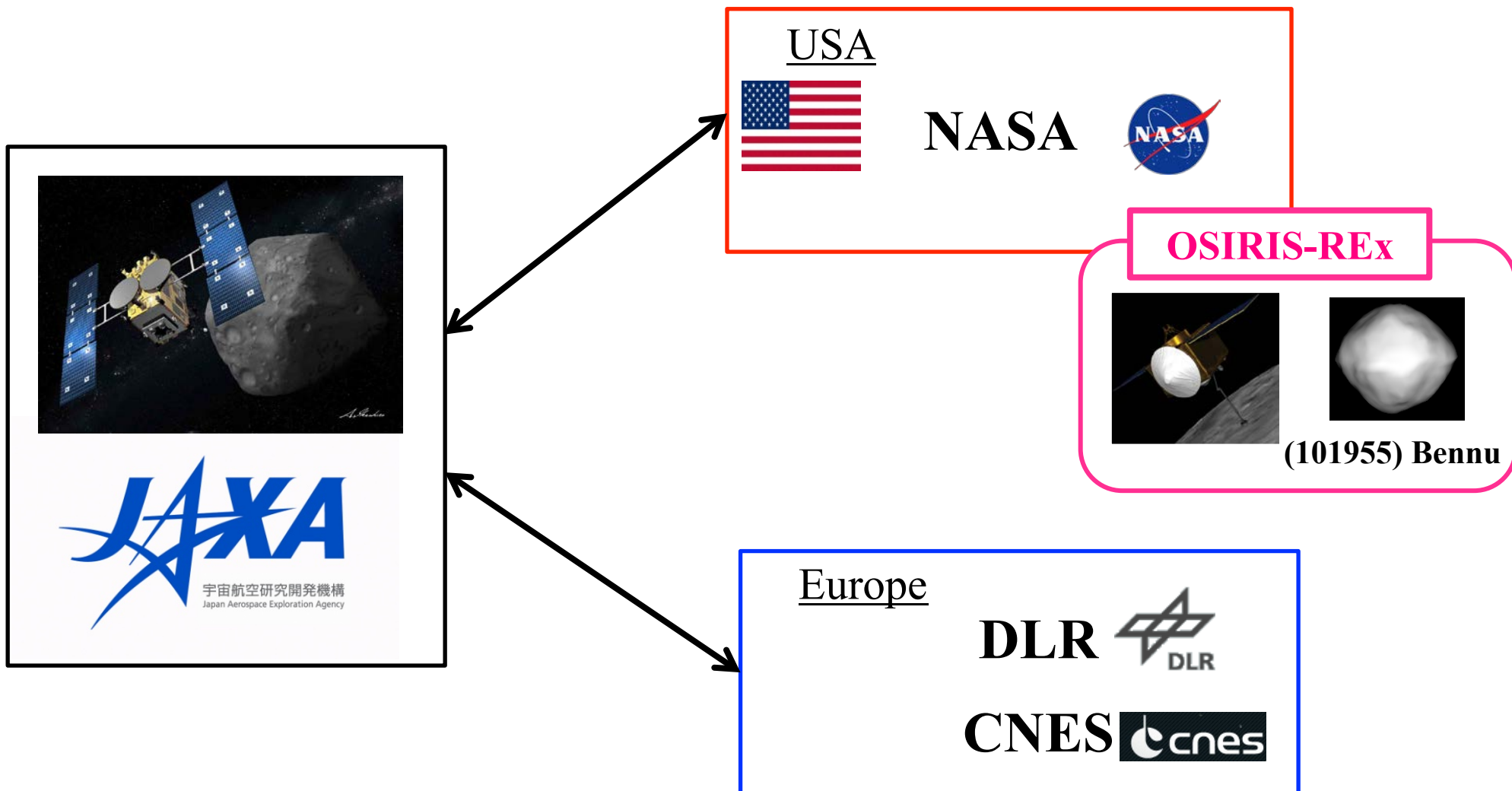



EU/US sample return missions



Japan
1999 JU3
(Ryugu)



2014
launch

U.S.
Bennu



2016
launch

(by JPL)

EU

2008 EV5

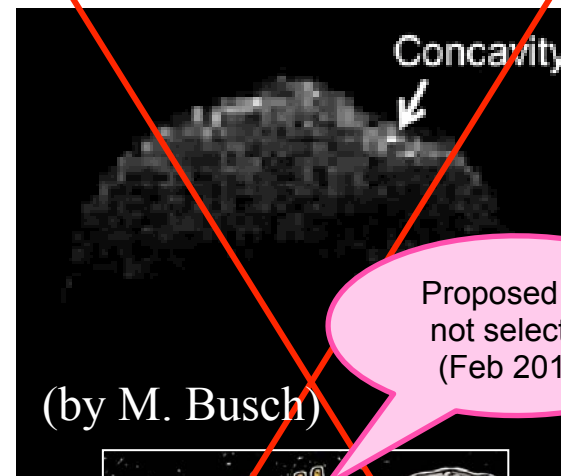

(by M. Busch)

Proposed but
not selected
(Feb 2014)



Hayabusa2

Cooperation

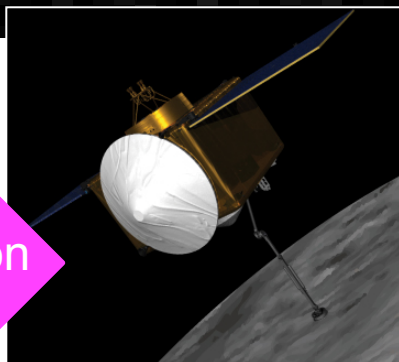

OSIRIS-REx

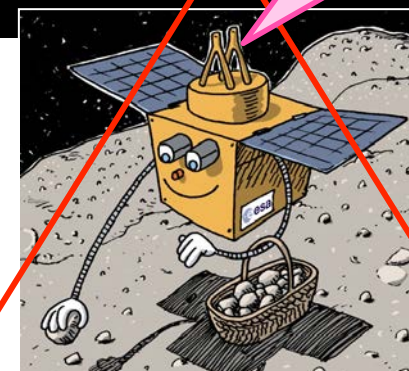

Marco Polo-R



Solar system origins

Comparison of mission target asteroids

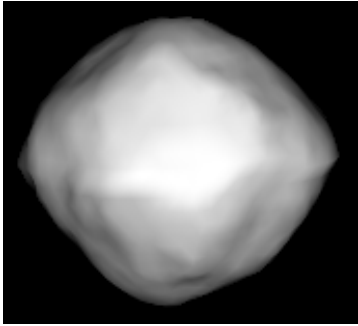
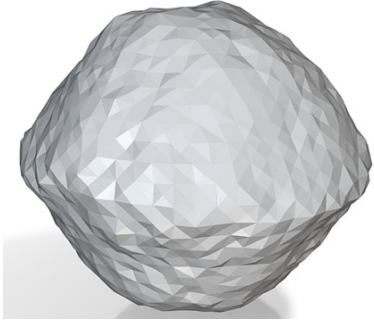
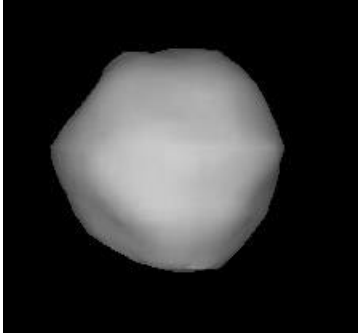
	(101955) Bennu 1999 RQ36	(341843) 2008 EV5	(65803) Didymos 1996 GT
Mission	OSIRIS-REx Sample return	MarcoPolo-R Sample return (not selected)	DART Impact
Type	B	C	Xk
Size	492 m	400 m	780 m
Shape	 (by D. Lauretta)	 (by M. Busch)	 (by NASA)
Period	4.297 h	3.725 h	2.2593 h
Axis	RA/Dec : 87/-65	RA/Dec : 105/-66	
Albedo	0.046	0.137	0.15
Note			binary



Orbits of Ryugu, Bennu, 2008 EV5



2018 / 6 / 21

